



DIRECT OPERATED PRESSURE RELIEF VALVE TYPE DBD

**WK
450 610**

NG 6, 10, 20

do 63 MPa

do 250 dm³/min.

04.1999r.

Pressure relief valves serve to limit maximum pressure in a whole hydraulic system or in a specified part of it. Direct operated pressure relief valves DBD are available, according to anticipated mounted method, as cartridge valves, for threaded connections and for subplate mounting.



DESCRIPTION OF OPERATION

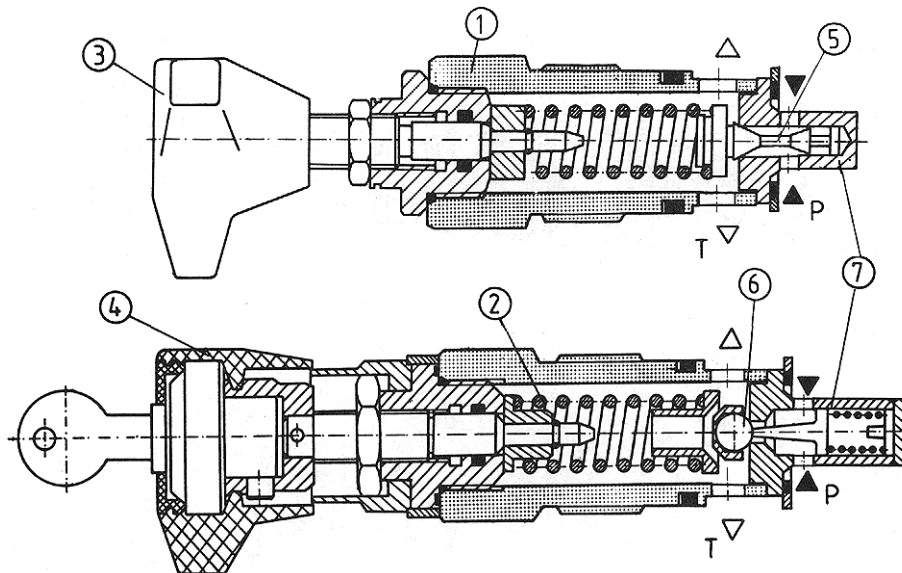

A moveable poppet (5) - in the valves for pressure up to 40 MPa and a ball (6) - in the valves size 10 for pressure up to 65 MPa represent the operating element.

Cracking pressure setting is made by variation of the tension of spring (2) by means of a handknob (3), lockable handwheel (4) or set screw.

Various ranges of pressure adjustment correspond to specific springs (exchangeable). A dumping element (7) is used to eliminate vibration of the valve.

TECHNICAL DATA

Hydraulic fluid	Mineral oil or phosphate ester		
Nominal fluid viscosity	37 mm ² /s at the temperature of 328 K		
Viscosity range	2.8 to 380 mm ² /s		
Optimum working temperature (fluid in a tank)	313 - 328 K		
Fluid temperature range	243 - 343 K		
Required fluid filtration	16 μm		
Recommended fluid filtration	10 μm		
Maximum operating pressure	Size 6	Size 10	Size 20
	40 MPa	63 MPa	40 MPa

OVERALL AND CONNECTION DIMENSIONS

Cartridge version

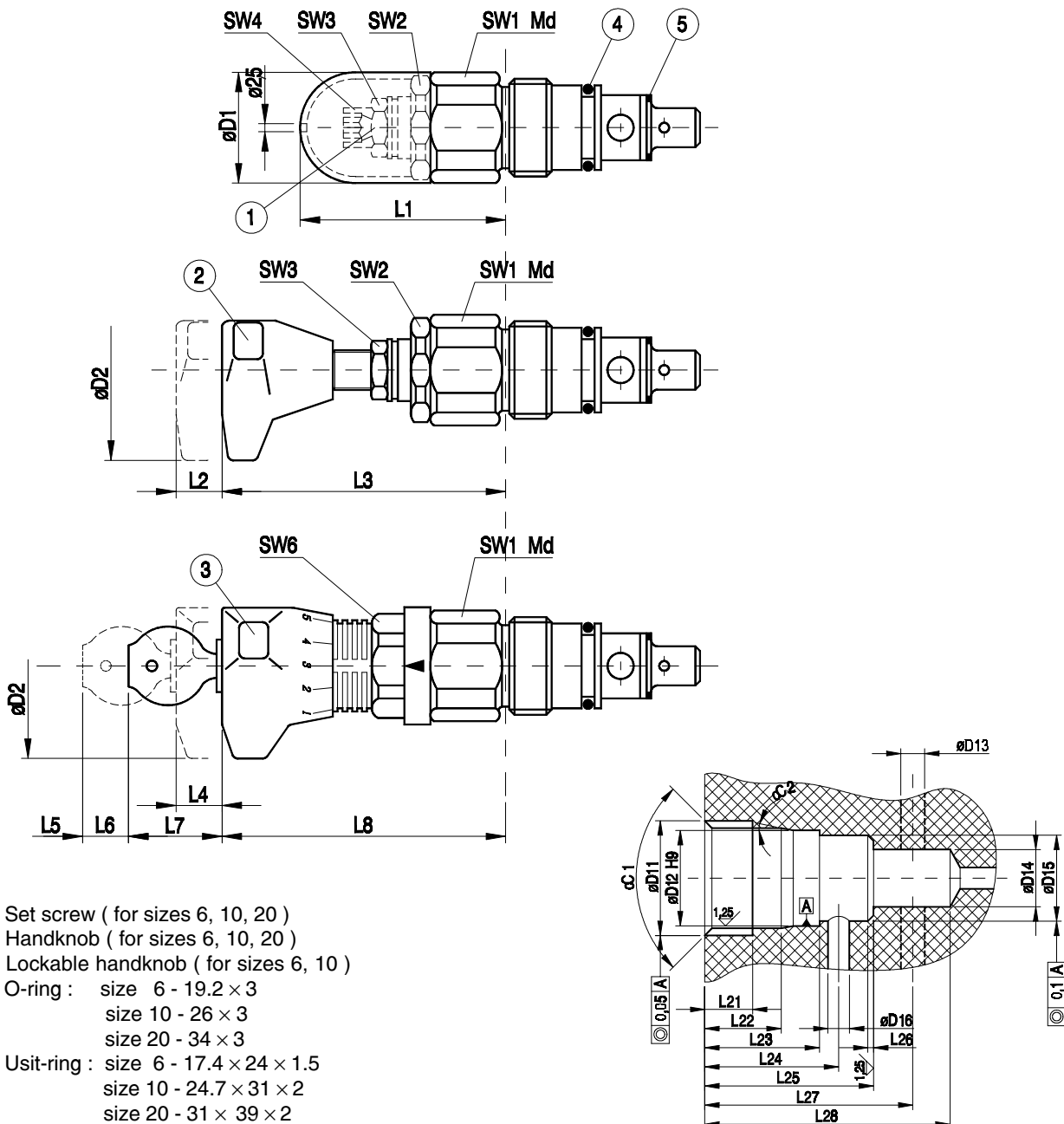

Valve	Weight [kg]	D1	D2	L1	L2	L3	L4	L5	L6	L7	L8	SW1	Md [Nm]	SW2	SW3	SW4	SW6
Size 6	0.4	34	60	72	11	20	11	20	11	30	94	32	80	30	19	6	3
Size 10	0.5	38	60	68	11	79	11	20	11	30	90	36	140	30	19	6	30
Size 20	1	48	60	65	11	77	-	-	-	-	-	46	170	36	19	6	-

Seat	D11	D12	D13	D14	D15	D16	L21	L22	L23	L24	L25	L26	L27	L28	$\alpha 1$	$\alpha 2$
Size 6	M28x1.5	25	6	15	24.9	6	15	19	30	35	45	0.5x45°	56.5±5	65	90	15
Size 10	M35x1.5	32	10	18.5	31.9	10	18	23	35	41	52	0.5x45°	67.5±7	80	90	15
Size 20	M45x1.5	40	20	24	39.9	20	21	27	45	54	70	0.5x45°	91.5±8	110	90	20

Cartridge version

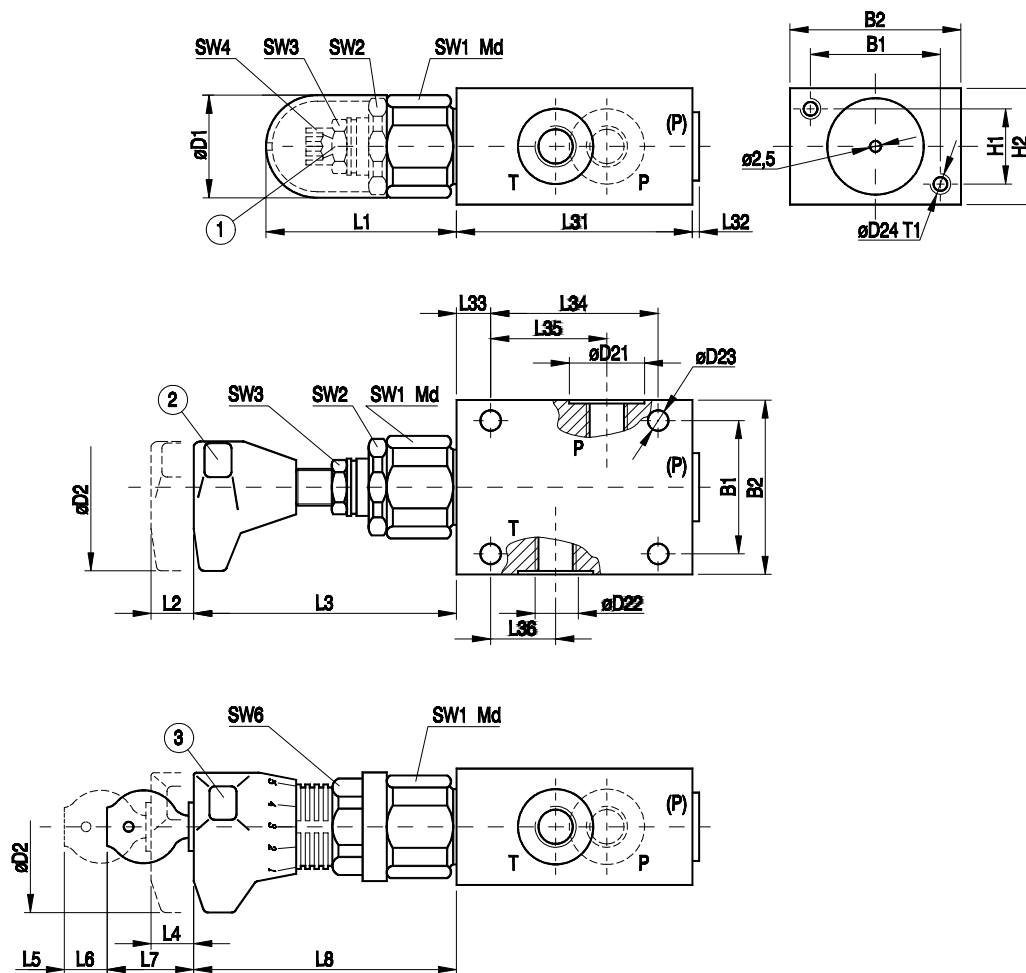

- 1 - Set screw (for sizes 6, 10, 20)
- 2 - Handknob (for sizes 6, 10, 20)
- 3 - Lockable handknob (for sizes 6, 10)

Valve	B1	B2	D1	D2	D21	D22	L23	L24	H1	H2	L1	L2	L3	L4	L5
Size 6	45	60	34	60	25	G1/4	6.6	M6	25	40	72	11	83	11	20
Size 10	60	80	38	60	34	G1/2	9	M8	40	60	68	11	79	11	20
Size 20	70	100	48	60	47	G1	9	M8	50	70	65	11	77	-	-

Valve	L6	L7	L8	L31	L32	L33	L34	L35	L36	SW1	SW2	SW3	SW4	SW6	T1	Weight
Size 6	11	30	94	80	3	15	55	40	20	32	30	19	6	30	10	1.6 kg
Size 10	11	30	90	100	4	20	70	49	21	36	30	19	6	11	20	3.7 kg
Size 20	-	-	-	135	5.5	20	100	65	34	46	36	19	6	-	20	7.0 kg

For subplate mounting version

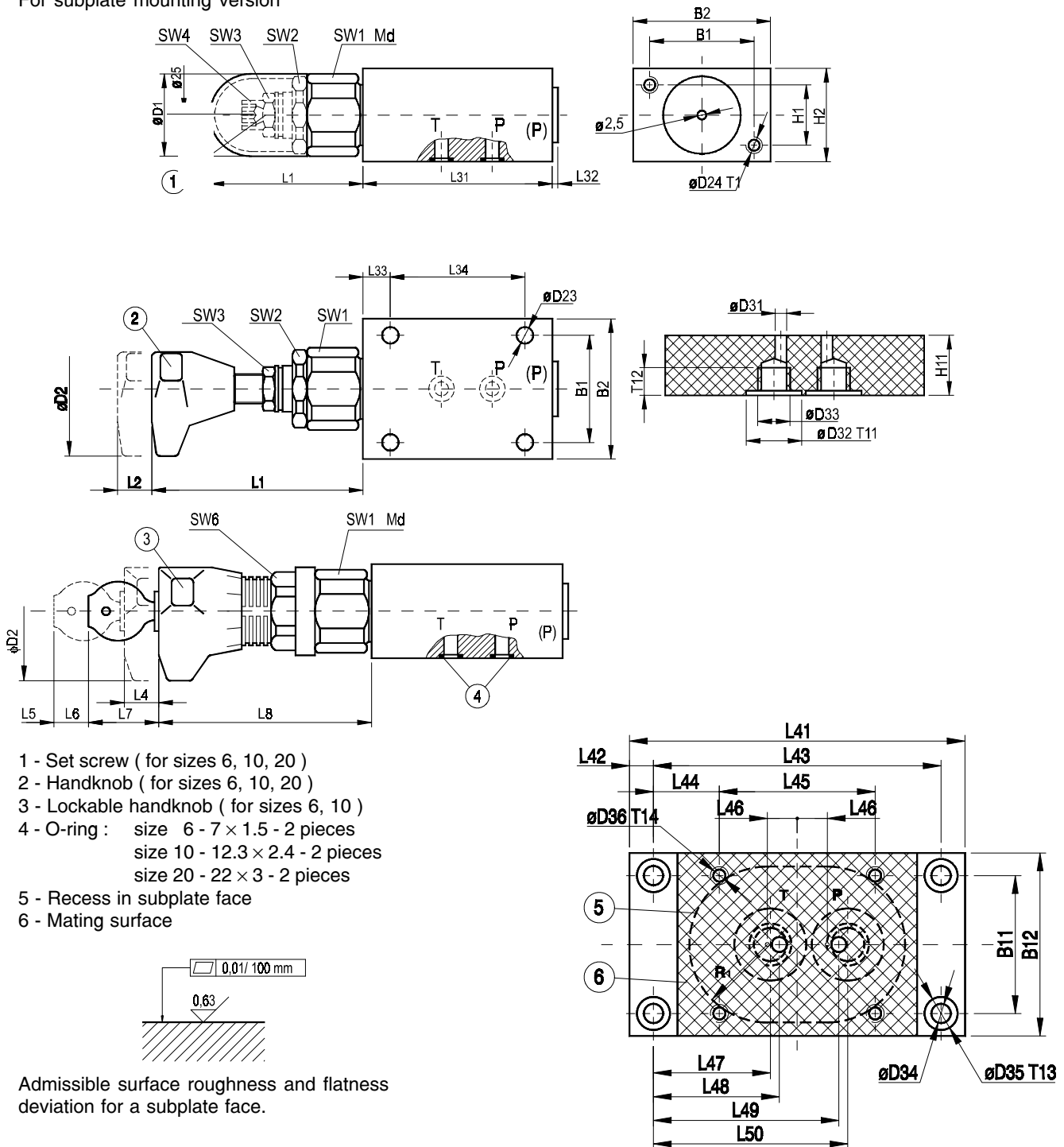

Valve	B1	B2	D1	D2	D23	D24	H1	H2	L1	L2	L3	L4	L5
Size 6	60	45	34	60	6.6	M6	25	40	72	11	83	11	20
Size 10	80	60	38	60	9	M8	40	60	68	11	79	11	20
Size 20	100	70	48	-	9	M8	50	70	65	11	77	-	-

L6	L7	L8	L31	L32	L33	L34	SW1	SW2	SW3	SW4	SW6	T1	Weight (kg)
11	30	94	80	3	15	55	32	30	19	6	30	10	1.6
11	30	90	100	4	20	70	36	30	19	6	30	20	3.7
11	-	-	135	5.5	20	100	46	36	19	6	-	20	7.0

Subplate	Type	Weight	B11	B12	D31	D32	D33	D34	D35	D36	H11	L41
Size 6	G300/01	1.5	45	60	6	25	G1/4	7	11	M6	25	110
Size 10	G302/01	2.0	60	80	10	34	G1/2	7	11	M8	25	135
Size 20	G304/01	5.5	70	100	20	47	G1	11.5	17.5	M8	40	170

L42	L43	L44	L45	L46	L47	L48	L49	L50	T11	T12	T13	T14	R1
8	94	22	55	10	39	42	62	65	1	15	9	15	25
10	115	27.5	70	12.5	40.5	48.5	72.5	80.5	1	16	9	15	30
15	140	20	100	20	42	54	85	97	1	20	13	22	40

	Bolts muonting the valve	Torque (Nm)	Standard
Size 6	M6 x 50 - 10.9	10	PN - 74 / M-82302 (DIN 912)
Size 10	M8 x 70 - 10.9	25	
Size 20	M8 x 90 - 10.9	25	

Note : Subplate and mounting bolts must be ordered seperately.

PERFORMANCE CURVES, measured at $v = 41 \text{ mm}^2/\text{s}$ and $T = 323 \text{ K}$

Operating pressure in flow-function.

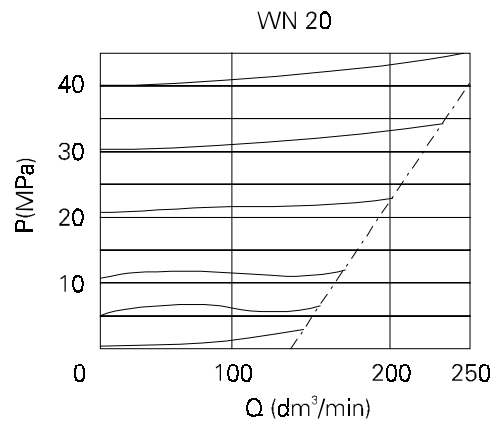
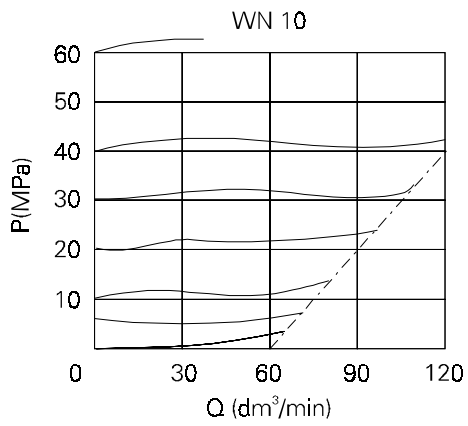
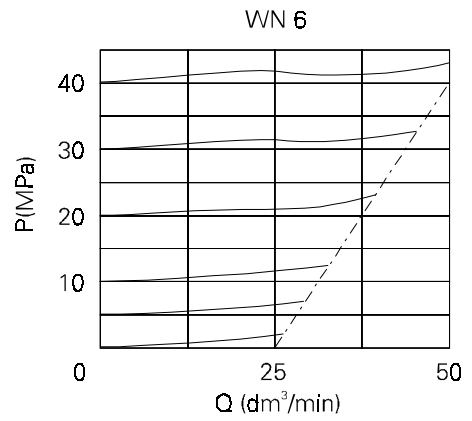

SCHEMES

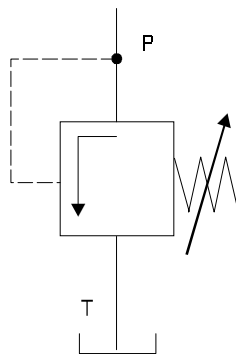

HOW TO ORDER

Orders coded in the way showed below should be forwarded to the manufacturer.

DBD				/		*
-----	--	--	--	---	--	---

Adjustment method

Set screw = S
 Handknob = H
 Lockable hand knob = A
 (for sizes 6 and 10 only)

Nominal size

Size 6 = 6
 Size 10 = 10
 Size 20 = 20

Mounting method

Cartridge version = K
 For threaded connection = G
 For subplate mounting = P

Series number

13 = 13
 (10 - 19) - installation and connection dimensions remain unchanged

Operating pressure range

up to 2.5 MPa = 25
 up to 5 MPa = 50
 up to 10 MPa = 100
 up to 20 MPa = 200
 up to 31.5 MPa = 315
 up to 40 MPa = 400
 up to 63 MPa = 630 (for size 10 only)

Sealing

Fluids on mineral oil base = with no code
 Fluids on phosphate-ester base = V

Further requirements in clear text (to be agreed with the manufacturer)

Coding example : DBD S 6 K 13/400

Version DBD... as a safety valve DBD6.../B and DBD10.../B meeting requirements TÜV

Flow curves

Size 6

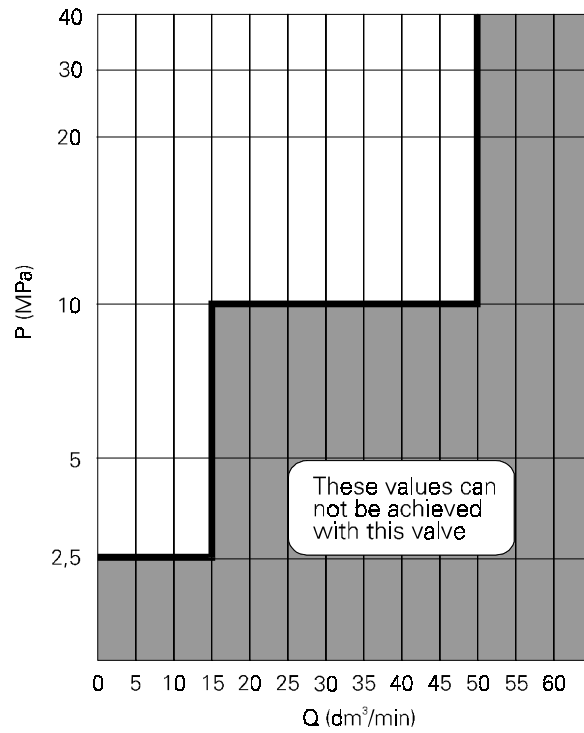

Size 10

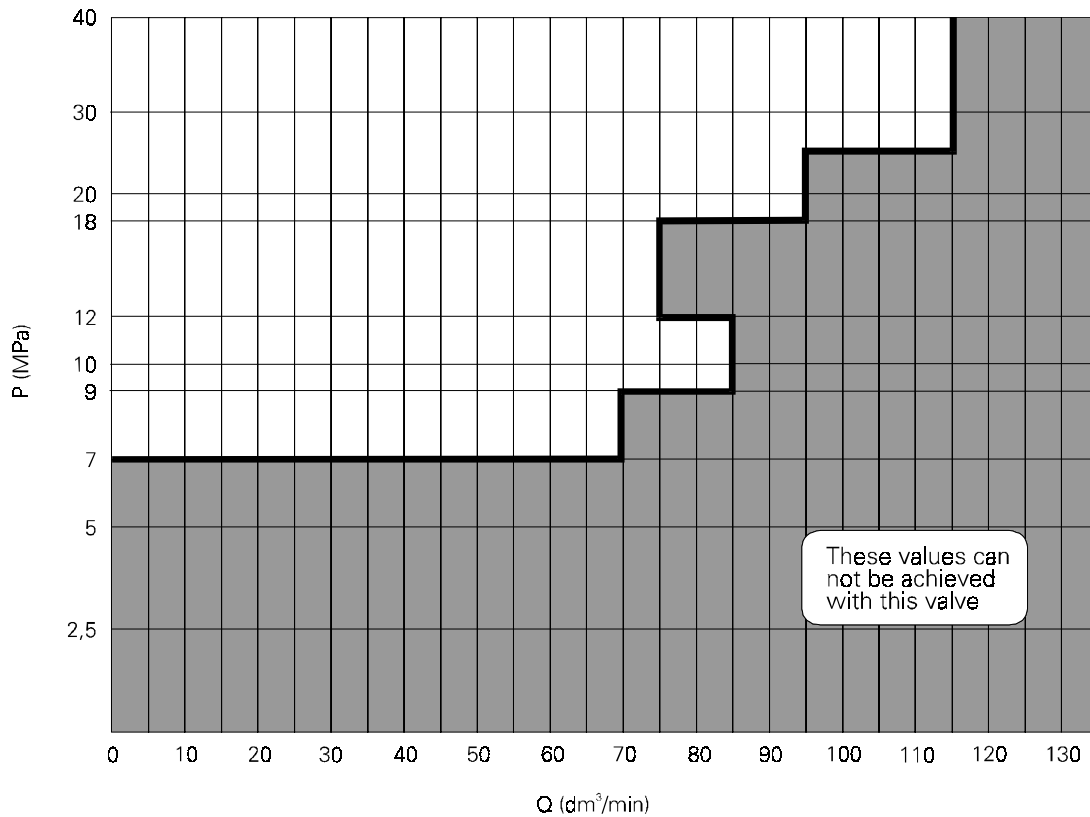

HOW TO ORDER

Orders coded in the way showed below should be forwarded to the manufacturer.



Nominal size	
Nominal size 6	= 6
Nominal size 10	= 10

Set pressure

Mounting method	
Cartridge version	= K
For threaded connection	= G
For subplate mounting	= P

Series number	
13	= 13
(10 - 19) - installation and connection dimensions remain unchanged	

Valve designation according to TÜV

Nominal size 6		Nominal size 10	
Pressure range MPa	Designation	Pressure range MPa	Designation
2,5 thr. 10,0 incl.	TÜV.SV.97-899.5.F.15 <input type="checkbox"/>	7,0 thr. 9,0 incl.	TÜV.SV.97-903.6.F.70 <input type="checkbox"/>
over 10,0 thr. 40,0	TÜV.SV.97-899.5.F.50 <input type="checkbox"/>	over 9,0 thr. 12,0 incl.	TÜV.SV.97-903.6.F.90 <input type="checkbox"/>
<input type="checkbox"/> pressure set at adjustment [bar]		over 12,0 thr. 18,0 incl.	TÜV.SV.97-903.6.F.80 <input type="checkbox"/>
		over 18,0 thr. 25,0 incl.	TÜV.SV.97-903.6.F.100 <input type="checkbox"/>
		over 25,0 thr. 40,0	TÜV.SV.97-903.6.F.120 <input type="checkbox"/>

Version DBD... as a safety valve DBD6.../JV and DBD10.../JV meeting requirements UDT

Flow curves

Size 6

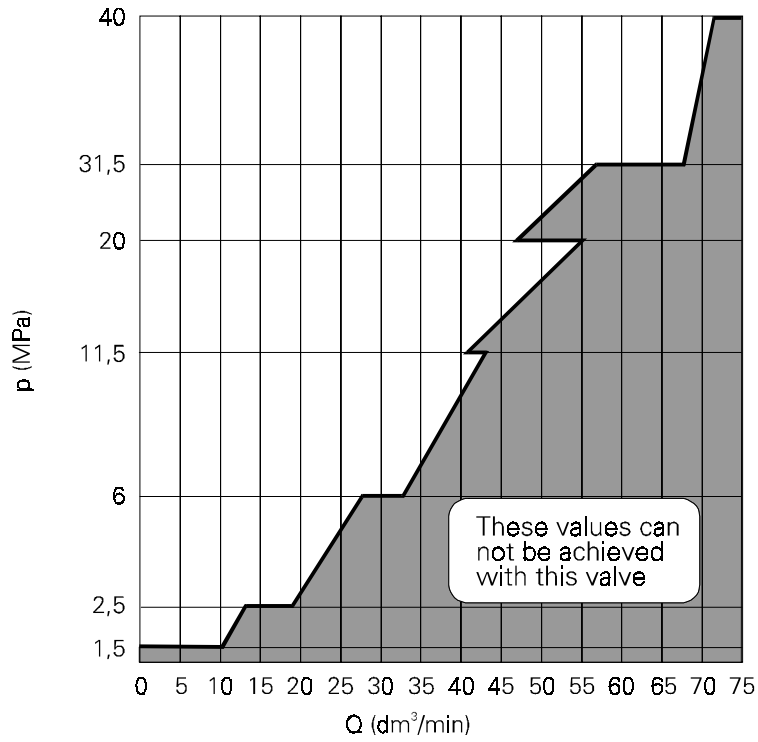

Size 10

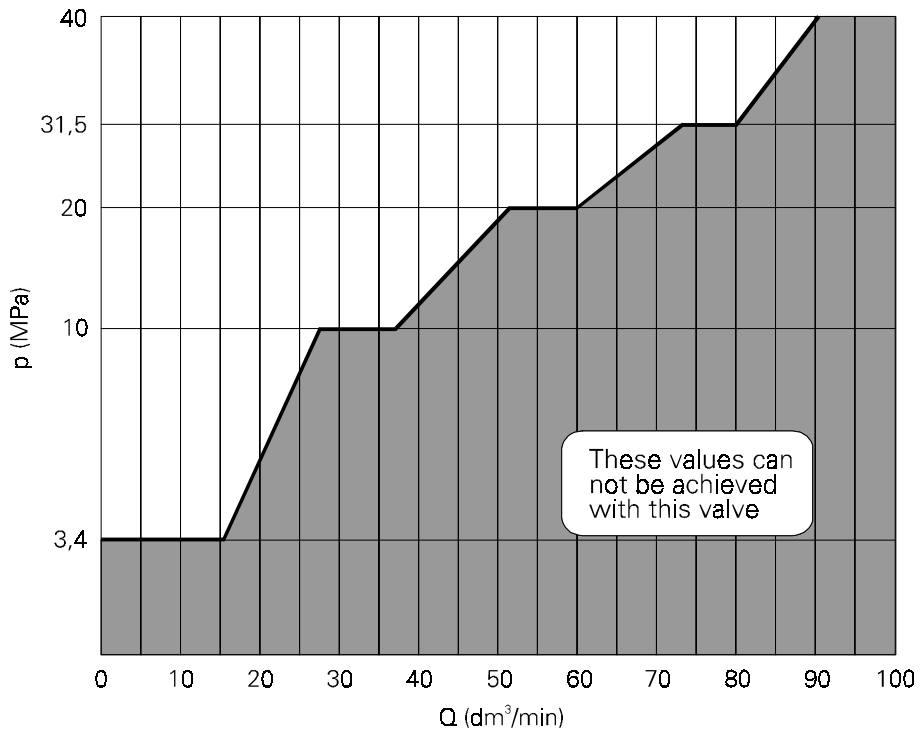

HOW TO ORDER

Orders coded in the way showed below should be forwarded to the manufacturer.

DBDS			/		JV
------	--	--	---	--	----

Nominal size	
Nominal size 6	= 6
Nominal size 10	= 10

Set pressure

Mounting method	
Cartridge version	= K
For threaded connection	= G
For subplate mounting	= P

Series number	
13	= 13
(10 - 19) - installation and connection dimensions remain unchanged	

Valve designation according to UDT

Nominal size 10 UDT.02.97.6.C.
 Nominal size 6 UDT.02.97.5.C.

- Pressure set [bar]
 Flow rate [dm³/min]

Nominal size 6			Nominal size 10		
Pressure range { bar }	Pressure (P) { bar }	Flow (W) { dm ³ / min }	Pressure range { bar }	Pressure (P) { bar }	Flow (W) { dm ³ / min }
5 ÷ 25	15	10,6	34 ÷ 55	34	16,5
	20	12,15		40	17,78
	25	13,7		50	19,92
25 ÷ 60			55 ÷ 100	55	21
	25	18,6		70	23,43
	30	20		90	26,68
	40	22,96		100	28,3
60 ÷ 115	50	25,87	100 ÷ 200	100	36,7
	60	31,8		130	41,29
	80	36,28		160	45,88
	100	40,76		200	52
115 ÷ 200	115	42	200 ÷ 315	200	60
	140	45,95		240	65,28
	160	49,11		280	70,56
	180	52,27		300	73,12
	200	55,4		315	75,2
200 ÷ 315	200	47,1	315 ÷ 400	315	80,3
	240	51,26		330	82,08
	280	55,42		360	85,65
	315	59,1		380	88,04
315 ÷ 400				400	90,4
	315	66			
	340	68,47			
	380	72,43			
	400	74,4			



Q-HYDRAULIKA, Rakovník
Rabasova 2281, 269 01 Rakovník, tel./fax: 313 514 718
e-mail: info@q-hydraulika.cz, www.q-hydraulika.cz