



# DIRECT OPERATED PRESSURE REDUCING VALVE TYPE DR5DP

**WK  
450 447**

**Size 5**

**21 MPa**

**15 dm<sup>3</sup>/min**

04.1999r.

Direct operated pressure reducing valve DR5DP is used to limit secondary pressure. It may be mounted in a hydraulic system in any position.



## DESCRIPTION OF OPERATION

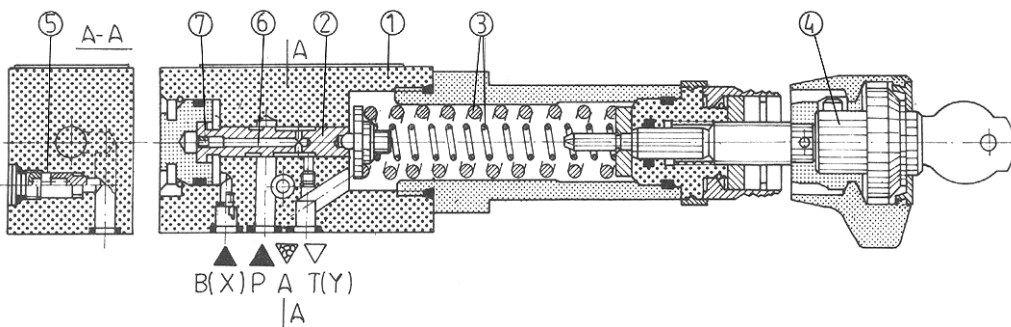

Pressure reducing valves consists basically of the housing 1, control spool 2, pressure springs 3, setting element 4 and optional check valve 5. A control element is the spool 2, which is held in neutral position in the housing 1 by the springs 3. In neutral position the valve is open. Oil flows from port P through the housing to port A. At the

same time pressure in port A affects the spool surface opposite the springs via control line 6. The control line 6 made in the moveable spool 2 is closed by the plug 7. If pressure at port A exceeds the value set at the spring, the spool 2 moves and reduces the flow from P to A. A check valve can be fitted in order to allow free return flow from port A to P.

## TECHNICAL DATA

Hydraulic fluid	Mineral oil or phosphate ester
Nominal fluid viscosity	37 mm <sup>2</sup> /s at the temperature of 328 K
Viscosity range	2.8 to 380 mm <sup>2</sup> /s
Optimum working temperature( fluid in a tank )	313 - 328 K
Fluid temperature range	243 - 343 K
Required fluid filtration	16 μm
Recommended fluid filtration	10 μm
Pressure in ports P, A, B ( X )	21 MPa
Backpressure pressure in port Y ( T )	6.0 MPa
Maximum flow rate	15 dm <sup>3</sup> /min
Weight	1.4 kg

# OVERALL DIMENSIONS

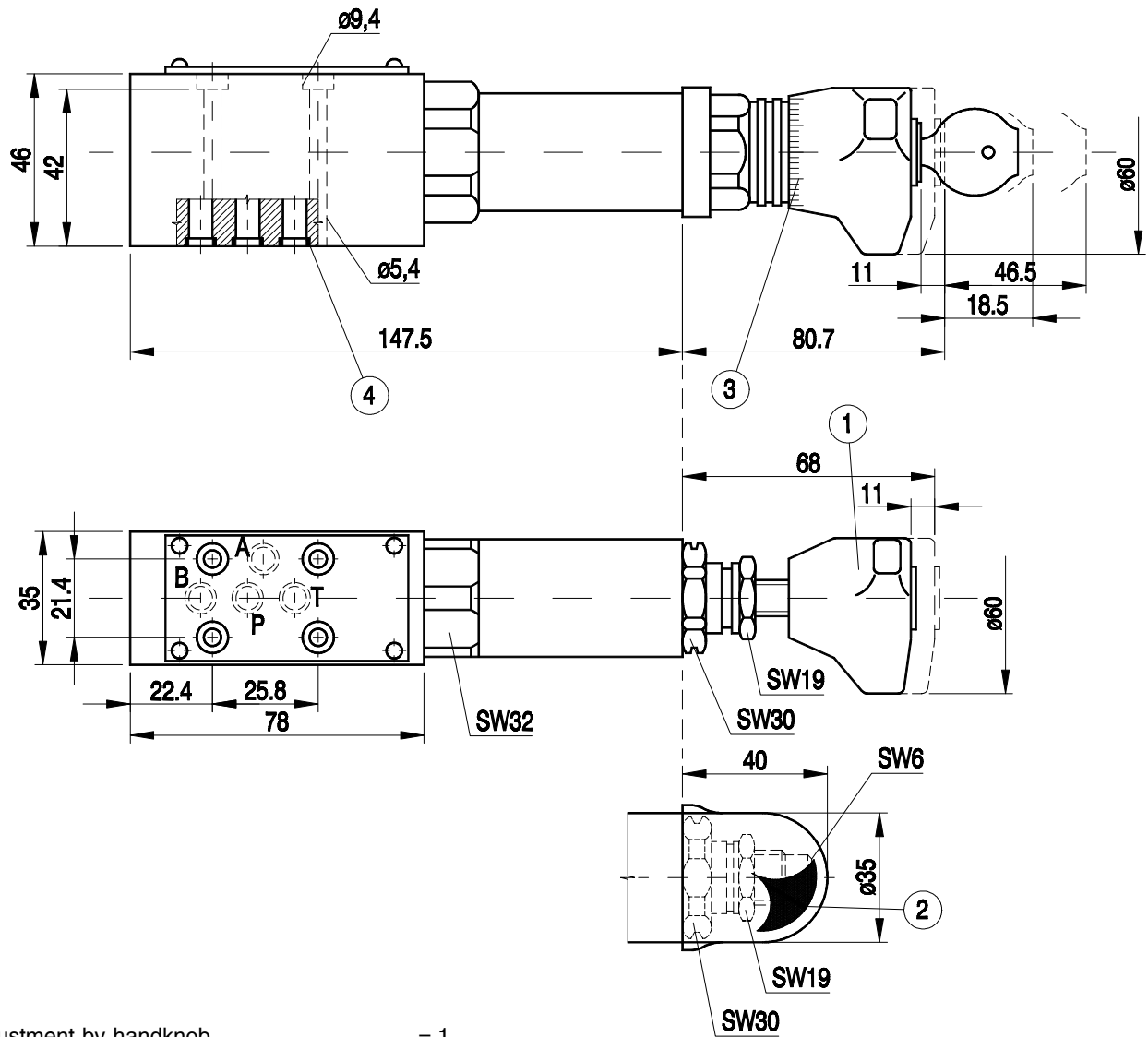

- 1 - Adjustment by handknob = 1
- 2 - Adjustment by sleeve with internal hexagon = 2
- 3 - Adjustment by lockable handknob = 3
- 4 - Sealing ring - o-ring 7 × 1.5 at ports P, A, Y (T), X (B) - 4 pcs

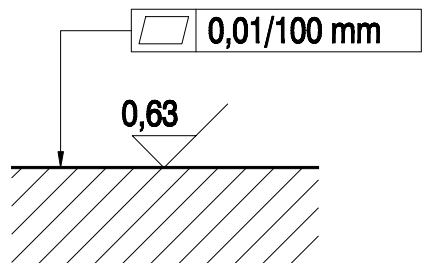

Admissible surface roughness and flatness deviation for a subplate face.

**PERFORMANCE CURVES,** measured at  $v = 41 \text{ mm}^2/\text{s}$  and  $T = 323 \text{ K}$

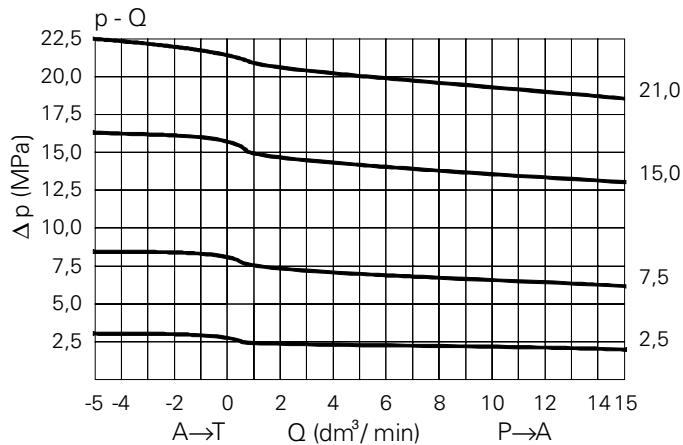

Pressure difference curve at inlet and outlet of the valve for particular pressure rate in relation to flow rate.

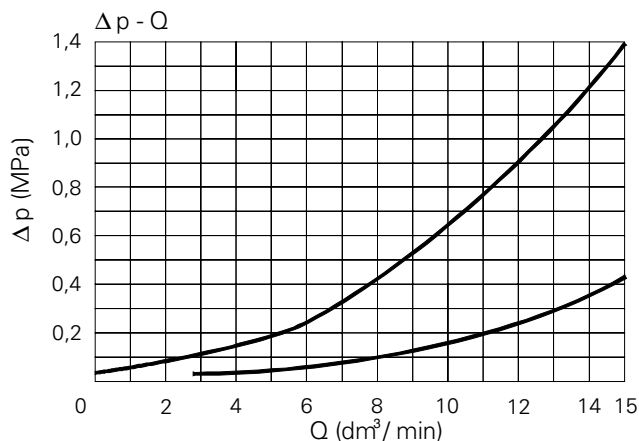

Pressure loss curve at flow through a built-in check valve  
 ————— pressure set  $p \leq 1.0 \text{ MPa}$   
 - - - - - pressure set  $p > 1.0 \text{ MPa}$

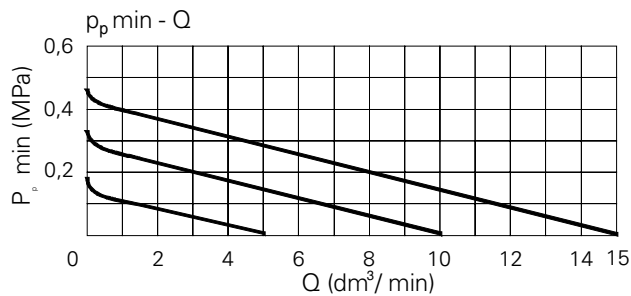

Secondary pressure increase curve for pressure set at flow decreasing to zero

## HOW TO ORDER

Orders coded in the way showed below should be forwarded to the manufacturer.

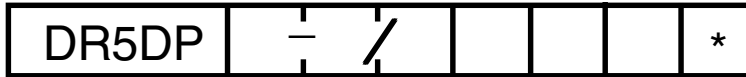

### Adjustment method

Hand knob	= 1
Sleeve with internal hexagon	= 2
Lockable hand knob	= 3

Further requirements in clear text  
( to be agreed upon with the manufacturer )

### Series number

20 = 20  
( 20 - 29 ) - installation and connection dimensions remain unchanged

### Sealing

Fluids on mineral oil base = with no code  
Fluids on phosphate-ester base = V

### Maximum secondary pressure

max 2.5 MPa	= 25
max 7.5 MPa	= 75
max 15.0 MPa	= 150
max 21.0 MPa	= 210

### Check valve

With check valve = with no code  
Without check valve = M

### Pilot supply and drain

Pilot supply internal, drain external = Y  
Pilot supply external, drain external = XY

Coding example : DR5DP1-20/75Y

## CONNECTION DIMENSIONS FOR SUBPLATE

Subplate G115/01 ( G 1/4 ) Weight 0.7 kg

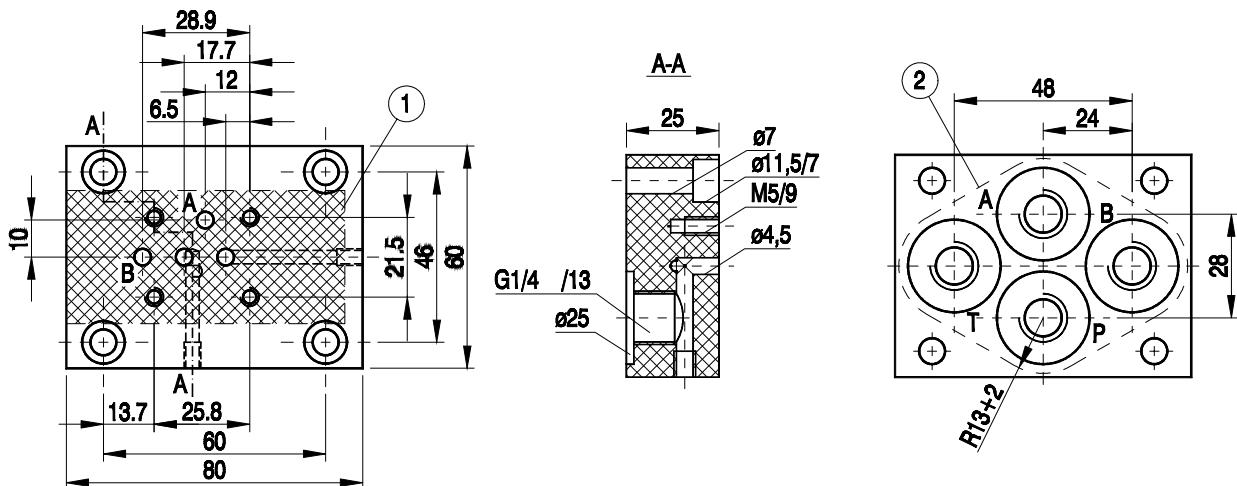

Subplate G96/01 ( G 1/4 ) Weight 0.7 kg

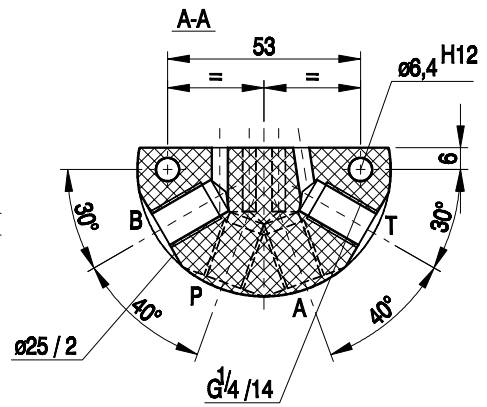
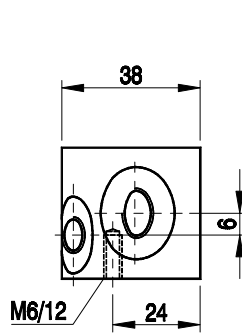
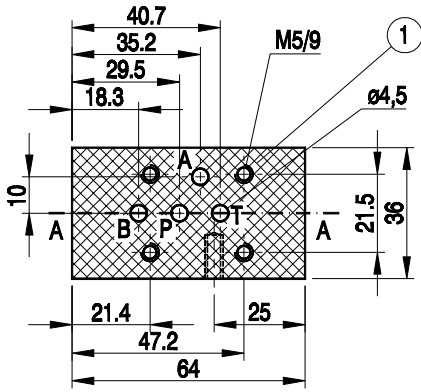

- 1 - Mounting face of valve
- 2 - Recess in subplate face
- 3 - Mounting bolts - M5x50-8.8 PN - 87/M-82302 ( DIN 912 )  
- 4 pcs ; Tightening torque = 9 Nm

Note : Subplate and fixing bolts have to be ordered separately

Graphical symbol

	Internal pilot supply External pilot drain	External pilot supply Internal pilot drain
without check valve	<p>YM</p>	<p>XYM</p>
with check valve	<p>Y</p>	<p>XY</p>

NOTES :



**Q-HYDRAULIKA, Rakovník**  
Rabasova 2281, 269 01 Rakovník, tel./fax: 313 514 718  
e-mail: [info@q-hydraulika.cz](mailto:info@q-hydraulika.cz), [www.q-hydraulika.cz](http://www.q-hydraulika.cz)