



PRESSURE SEQUENCE VALVE TYPE UZKC 6

**WK
493 061**

NG 6

21 MPa

30 dm³/min.

04.2000r.

The function of pressure sequence valves, sandwich plate design, type UZKC 6 is to sequencing control of hydraulic system pressure. They may also be used as direct operated relief valves.



DESCRIPTION OF OPERATION

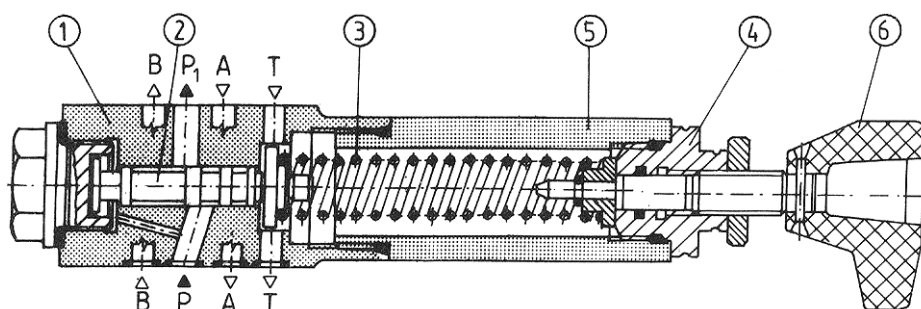

The spring force is set by turning the hand knob 6 of the adjustment 4. If control pressure exceeds the value set at the spring 3, the spool 2 moves and opens the flow path from P to P1.

The spool valve 2 in the housing 1 is affected by input pressure in line P on one side and by the force of the spring 3 dependent on its deflection on the other.

TECHNICAL DATA

Hydraulic fluid	Mineral oil or phosphate ester
Nominal fluid viscosity	37 mm ² /s at the temperature of 328 K
Viscosity range	2.8 to 380 mm ² /s
Optimum working temperature(fluid in a tank)	313 - 328 K
Fluid temperature range	243 - 343 K
Required fluid filtration	16 μm
Recommended fluid filtration	10 μm
Maximum pressure in ports A, B, P	31.5 MPa
Maximum pressure setting in port A or P (while in port T = 0 MPa)	21 MPa
Maximum pressure in port T	1.5 MPa
Weight	~ 1.2 kg

OVERALL DIMENSIONS

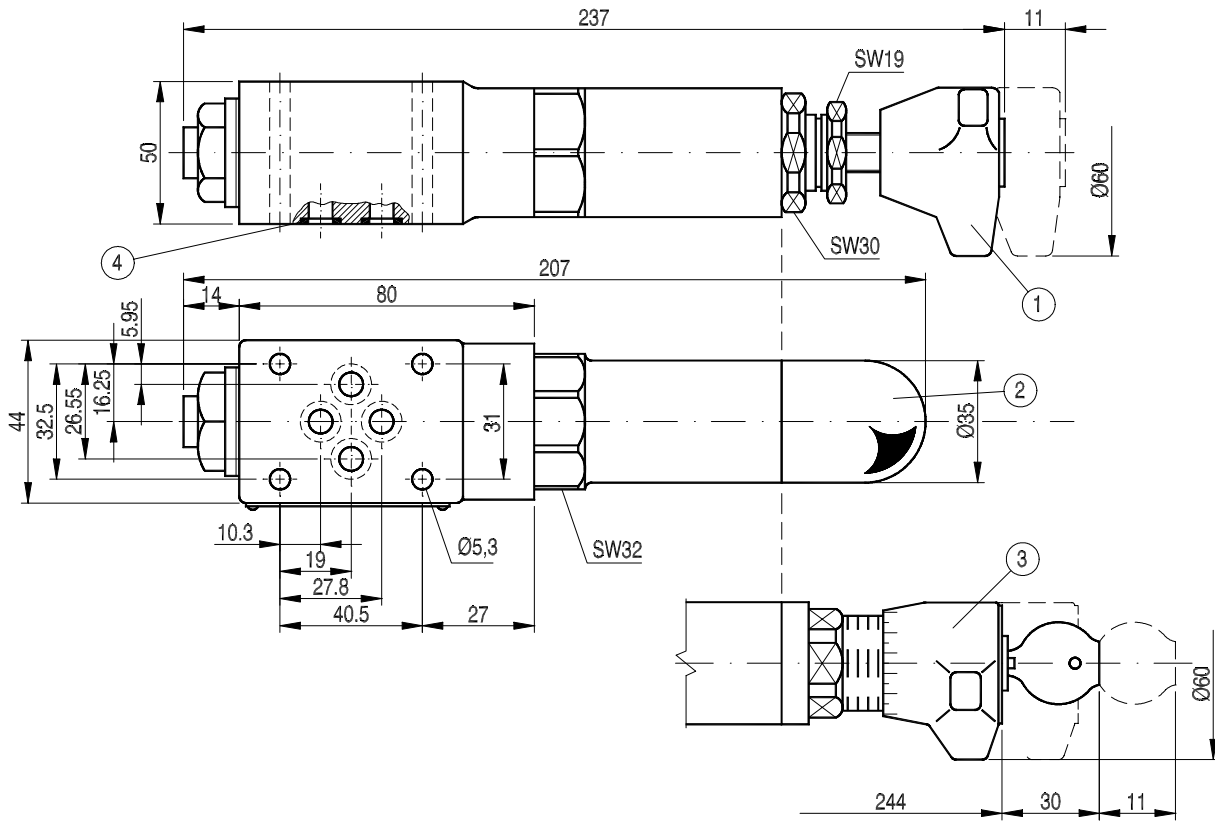

- 1 - Hand knob
- 2 - Set screw
- 3 - Lockable hand knob
- 4 - O-ring 9.2 × 1.8 - 4 pcs

Admissible surface roughness and flatness deviation for a subplate face.

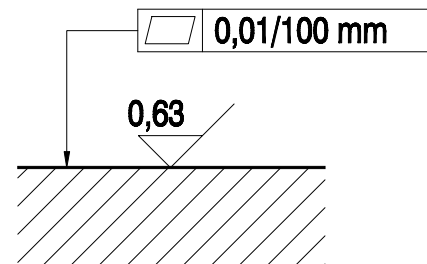

PERFORMANCE CURVES, measured at $v = 41 \text{ mm}^2/\text{s}$ and $T = 323 \text{ K}$

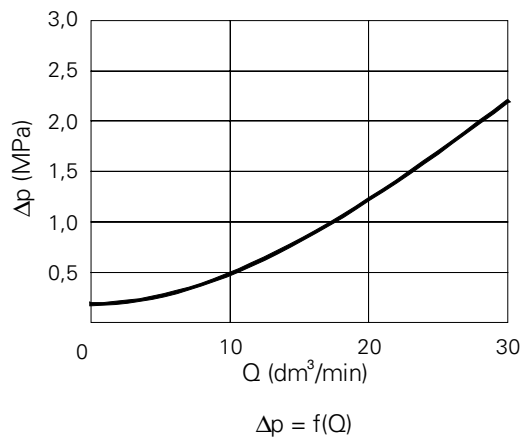

Pressure drop at check valve in relation to flow rate.

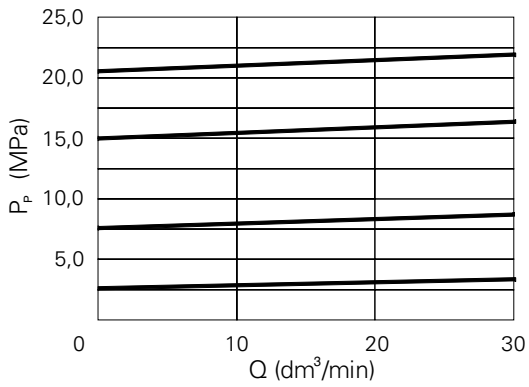

$$P_p = f(Q)$$

Input pressure in relation to flow rate

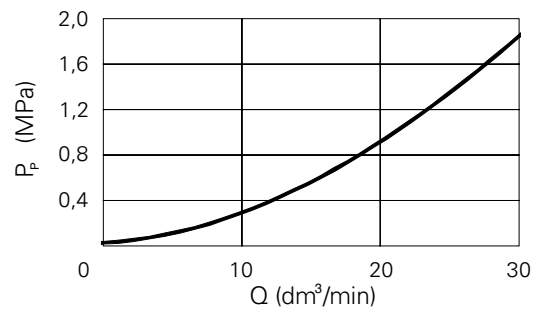

$$P_p = f(Q)$$

Minimum input pressure in relation to flow rate

HYDRAULIC SCHEMES

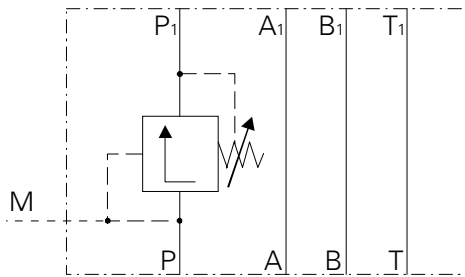

UZKC 6/32 -...-W-...-P-...

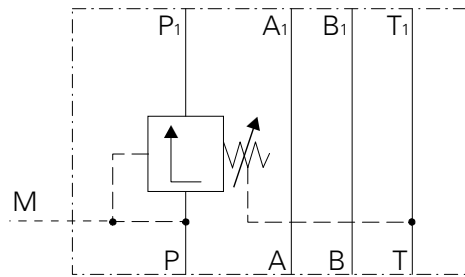

UZKC 6/32 -...-Y-...-P-...

HOW TO ORDER

Orders coded in the way showed below should be forwarded to the manufacturer.

UZKC 6 / - - - - - *

Series number
 32 =32
 (30 - 39) - installation and connection dimensions remain unchanged

Set pressure range
 up to 2.5 MPa = 25
 up to 7.5 MPa = 75
 up to 15 MPa = 150
 up to 21 MPa = 210

Pilot fluid supply and drain
 Internal supply, internal drain = W
 Internal supply, external drain = Y

Adjustment method
 Hand knob = 1
 Set screw = 2
 Lockable hand knob = 3

Further requirements in clear text
 (to be agreed upon with the manufacturer)

Sealing
 Fluids on mineral oil base = with no code
 Fluids on phosphate-ester base = V

Valve location
 Valve in line P = P
 Valve in line A = A

Accessories
 Without accessories = no code
 With chack valve = Z
 (for valves in line A only)

Coding example : UZKC 6/ 32 - 25 - Y - 1 - P

CONNECTION DIMENSIONS FOR SUBPLATE

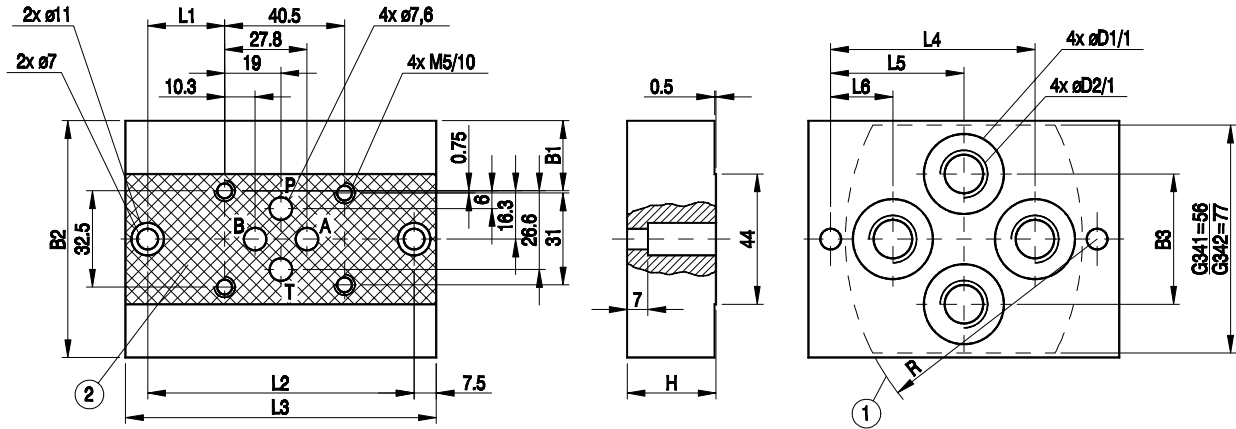

1 - Recess in subplate

Type	B1	B2	B3	L1	L2	L3	L4	L5	L6	H	D1	D2	R	T
G341/01	12.7	58	34	21	80	95	55	40	25	25	22	G 1/4	70	13
G342/01	23.7	80	44	26	90	105	69	45	21	30	28	G 3/8	85	13
G341/02	12.7	58	34	21	80	95	55	40	25	25	22	M14x1.5	70	15
G342/02	23.7	80	44	26	90	105	69	45	21	30	27	M16x1.5	85	15

Weight of subplate type G 341 ... ~ 1 kg

Weight of subplate type G 342 ... ~ 1.9 kg

Fixing the valve to the subplate by means of 4 bolts M5 x L
- 10.9 PN-74/M-82302 (DIN 912 - 10.9) long according to
the number of mounted components.

Tightening torque - 8.8 Nm.

Subplate and fixing bolts have to be ordered separately.



Q-HYDRAULIKA, Rakovník
Rabasova 2281, 269 01 Rakovník, tel./fax: 313 514 718
e-mail: info@q-hydraulika.cz, www.q-hydraulika.cz