



Pressure reducing valve type UZRB 6

**WK
493 220**

NG 6

21 MPa

30 dm³/min

04.2000r.

Pressure reducing valve for subplate mounting type UZRB6 is used to maintain pressure behind the valve constant, on condition that pressure in front of the valve is higher. The valve may also be applied where undesirable pressure increase behind the valve could appear. An additional connection to a tank is then open in order to reduce excessive pressure increase.



DESCRIPTION OF OPERATION

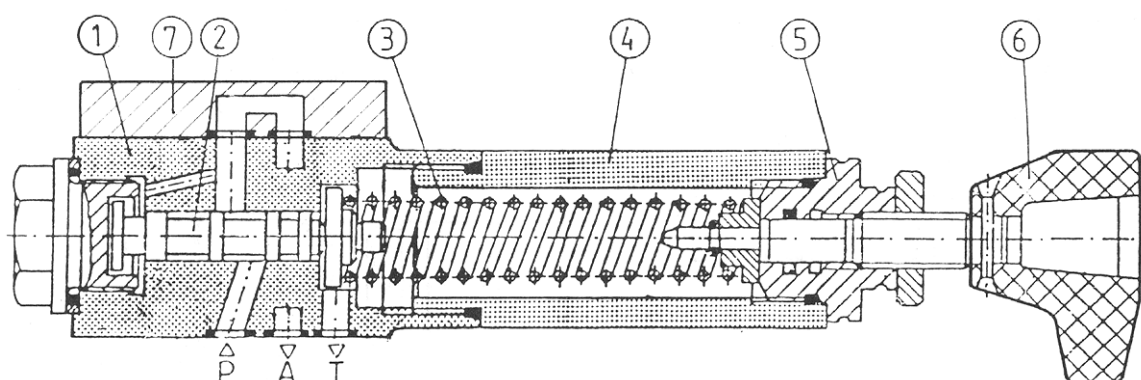

The spool 2 is held in neutral position in the housing 1 by the spring 3. At the same time pressure in line A affects the spool surface opposite the spring. The valve is open in initial position. The spring force is set by turning the hand knob 6 of the setting element 5, which is screwed in the sleeve 4. If pressure exceeds the value set at the spring, the spool moves along and reduces the flow from P to A.

Thus larger restriction of the flow will follow and as a result pressure behind the valve will be limited. If pressure in line A continues to rise, connection from P to A is cut off. The spool 2 is pushed further against the spring and line A is connected to T. Oil drains until pressure stops to increase.

TECHNICAL DATA

Hydraulic fluid	Mineral oil or phosphate ester
Maximum pressure at line P	31,5 MPa
Maximum pressure at line A (at T = 0 MPa)	21 MPa
Maximum pressure at line T	1,5 MPa
Nominal fluid viscosity	37 mm ² /s at temp. 328 K
Viscosity range	2,8 to 380 mm ² /s
Optimum working temperature (fluid in a tank)	313 - 328 K
Fluid temperature range	243 - 343 K
Required fluid filtration	16 mm
Recommended fluid filtration	10 mm
Weight	~ 1.4 kg

OVERALL DIMENSIONS

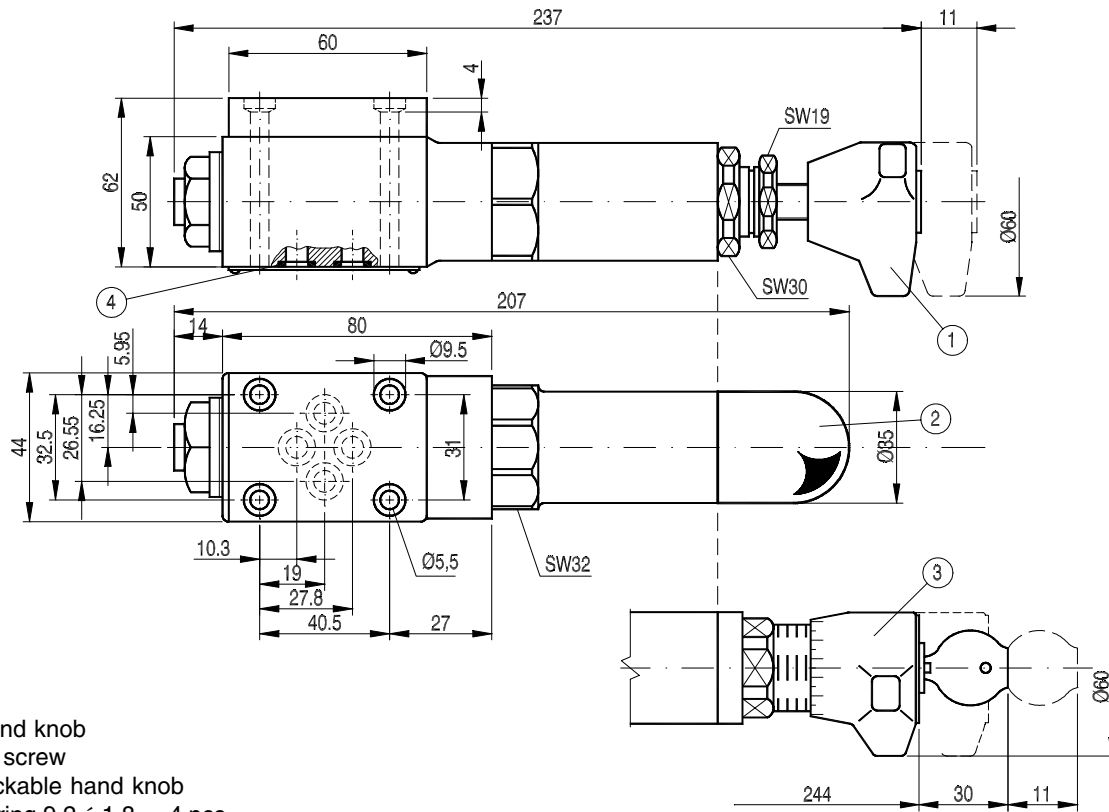

- 1 - hand knob
- 2 - set screw
- 3 - lockable hand knob
- 4 - O-ring 9.2 x 1.8 - 4 pcs

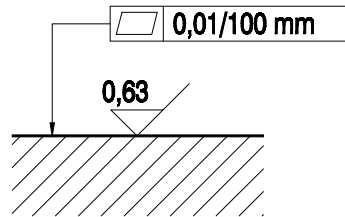

Required surface finish of the mating subplate.

OPERATING CURVES, at $n = 41 \text{ mm}^2/\text{s}$, temp. = 323 K

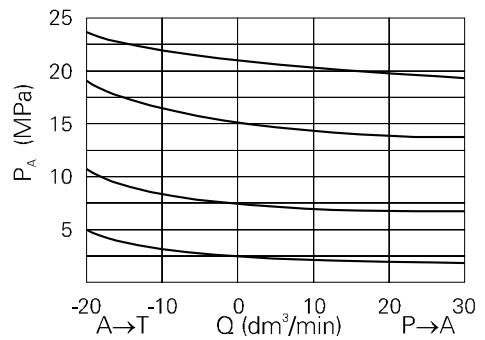

$P_A = f(Q)$ - output pressure in relation to flow rate

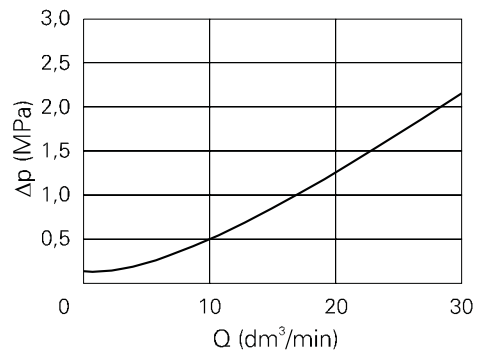

$\Delta p = f(Q)$ - pressure drop at check valve in relation to flow rate

$D_{pAmin} = f(Q)$ - effect of flow changes in line P-A on output pressure.

If, for example, pressure in line A is set at 3 MPa with flow rate 7 dm³/min, output pressure increases to $P_A = 3.4$ MPa as flow decreases towards $Q = 0$ dm³/min.

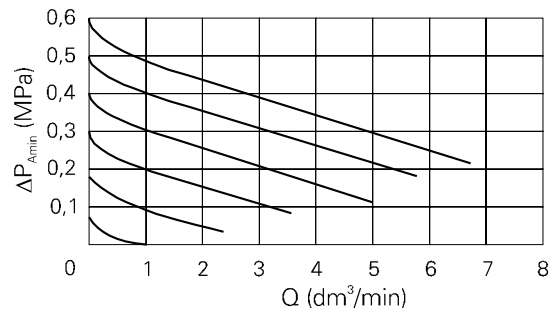

HYDRAULIC DIAGRAMS

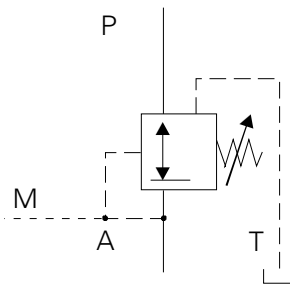

UZRB 6/22 ----Y...

HOW TO ORDER

Orders coded as below should be forwarded to the manufacturer.

UZR	B	6	/	-	-	Y	-	-	*
------------	----------	----------	---	---	---	----------	---	---	---

Series number 22 (20 - 29) - installation and connection dimensions remain unchanged = 22

Set pressure range Do 2.5 MPa = 25 Do 7.5 MPa = 75 Do 15 MPa = 150 Do 21 MPa = 210

Pilot fluid supply and drain Internal pilot supply, external pilot drain via line T = Y

Setting element Hand knob = 1 Set screw = 2 Lockable hand knob = 3
--

Sealing Seals suitable for mineral oils = no design. Seals suitable for phosphate ester = V
--

Further requirements in clear text (to be agreed with the manufacturer)

Coding example:
UZR B 6 / 22 - 25 - Y - 2

CONNECTION DIMENSIONS FOR SUBPLATE

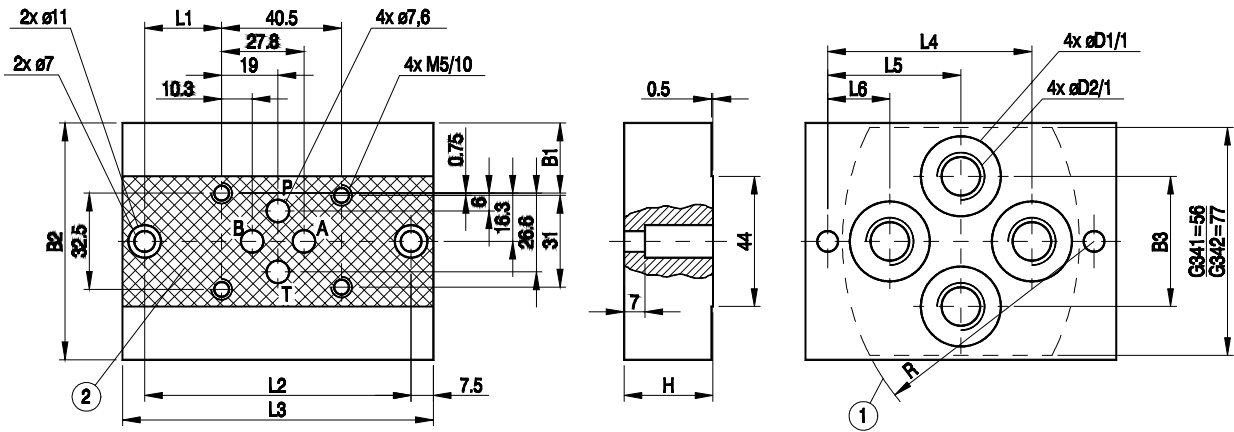

1 - Recess in subplate

Type	B1	B2	B3	L1	L2	L3	L4	L5	L6	H	D1	D2	R	T
G341/01	12.7	58	34	21	80	95	55	40	25	25	22	G 1/4	70	13
G342/01	23.7	80	44	26	90	105	69	45	21	30	28	G 3/8	85	13
G341/02	12.7	58	34	21	80	95	55	40	25	25	22	M14x1.5	70	15
G342/02	23.7	80	44	26	90	105	69	45	21	30	27	M16x1.5	85	15

Weight of subplate G 341 ... ~ 1 kg
 Weight of subplate G 342 ... ~ 1.9 kg

Subplate must be ordered separately..

Fixing the valve to the subplate should be done by means of 4 bolts M5 x 65 - 10.9 PN-74/M-82302 (DIN 912 - 10.9)
 Tightening torque - 9 Nm.



Q-HYDRAULIKA, Rakovník
Rabasova 2281, 269 01 Rakovník, tel./fax: 313 514 718
e-mail: info@q-hydraulika.cz, www.q-hydraulika.cz