



CHECK VALVE TYPE UZZB 10 FOR SUBPLATE MOUNTING

**WK
450 347**

Size 10

up to 31.5 MPa

60 dm³/min

04.1999r.

Check valves type UZZB 10 are used to close hydraulic fluid flow in one direction and allow free flow in the opposite direction.

The valves are for subplate mounting and can be installed in systems in any positions together with a connection plate.

Sealing of interfaces is provided by O-rings which are included.

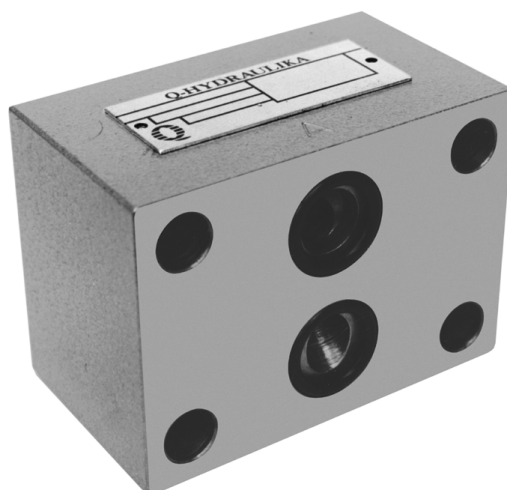

DESCRIPTION OF OPERATION

In the check valve type UZZB 10 the closing element is a poppet 2 pushed on to the seat in the housing 1. Flowing through the valve in the direction A to B fluid lifts the poppet from its seat and permits free flow. Cracking pressure depends on initial spring tension.

In the opposite direction B to A the spring and the fluid push the poppet on to the seat and close the connection without leakage.

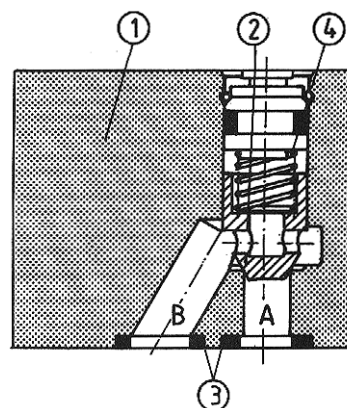

Item 3 - O-ring 16 × 3 - 2 pieces

TECHNICAL DATA

Hydraulic fluid	Mineral oil or phosphate ester
Nominal fluid viscosity	37 mm ² /s at the temperature of 328 K
Viscosity range	2.8 to 380 mm ² /s
Optimum working temperature (fluid in a tank)	313 - 328 K
Fluid temperature range	243 - 343 K
Required fluid filtration	16 μm
Recommended fluid filtration	10 μm
Maximum working pressure	31.5 MPa
Cracking pressure	0.05; 0.1; 0.15 ; 0.3 MPa
Weight	1.7 kg

OVERALL DIMENSIONS

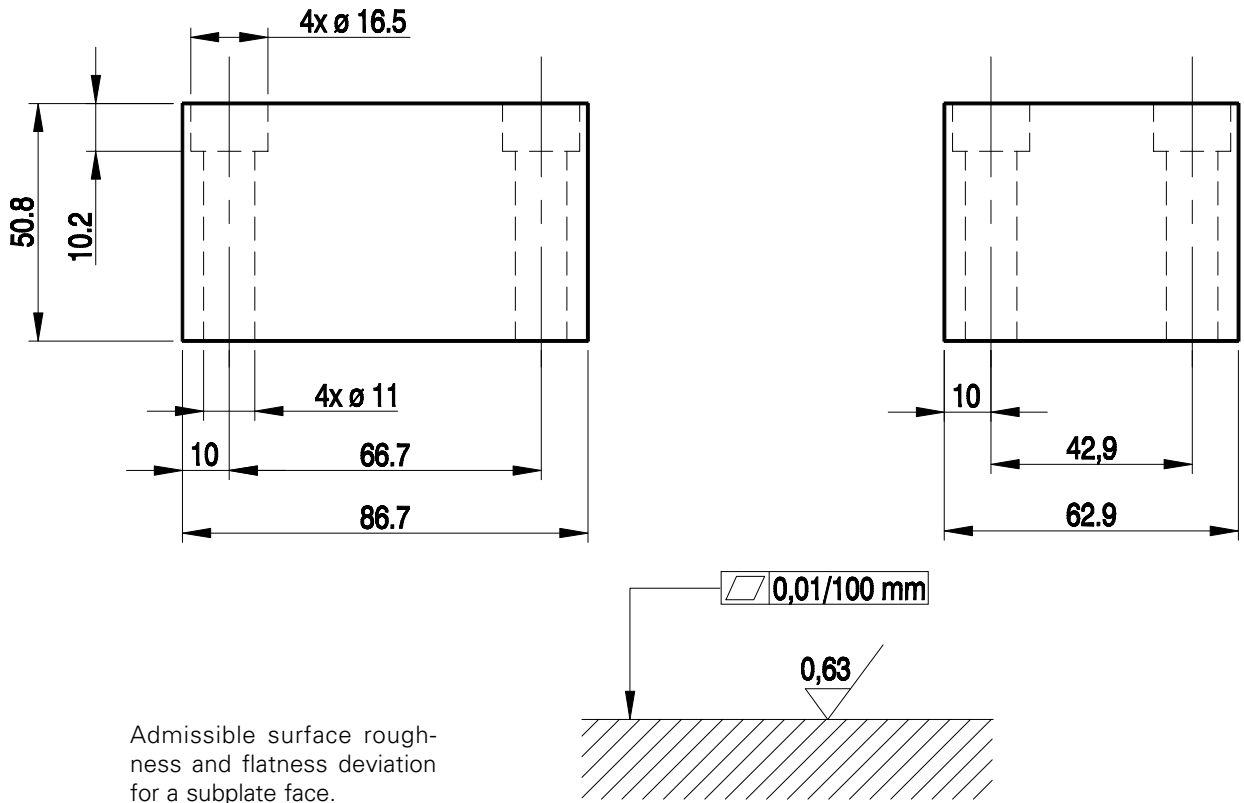

PERFORMANCE CURVES, measured at $v = 41 \text{ mm}^2/\text{s}$ and $T = 323 \text{ K}$

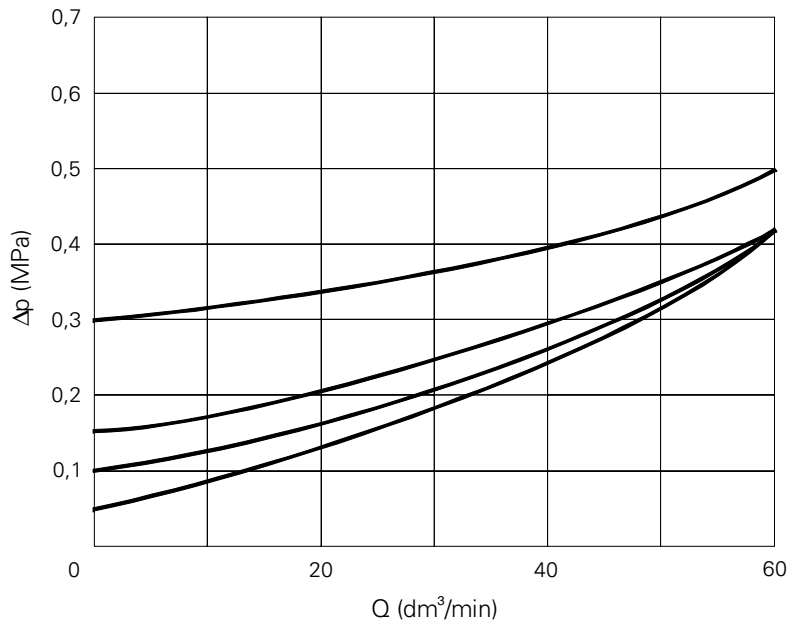

SCHEME

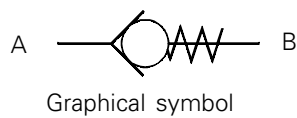

HOW TO ORDER

Orders coded in the way showed below should be forwarded to the manufacturer.

UZZB 10 - / - *

Series number :
 20 = 20
 (20-29) - installation and connection
 dimensions unchanged

Additional requirements in clear text
 (to be agreed with the manufacturer)

Cracking pressure
 Without spring = 00
 Cracking pressure 0.05 MPa = 05
 Cracking pressure 0.10 MPa = 10
 Cracking pressure 0.15 MPa = 15
 Cracking pressure 0.30 MPa = 30

Sealing
 Fluids on mineral oil base = no designation
 Fluids on phosphate ester base = V

Coding example : UZZB 10 - 20/10

CONNECTION DIMENSIONS FOR A SUBPLATE

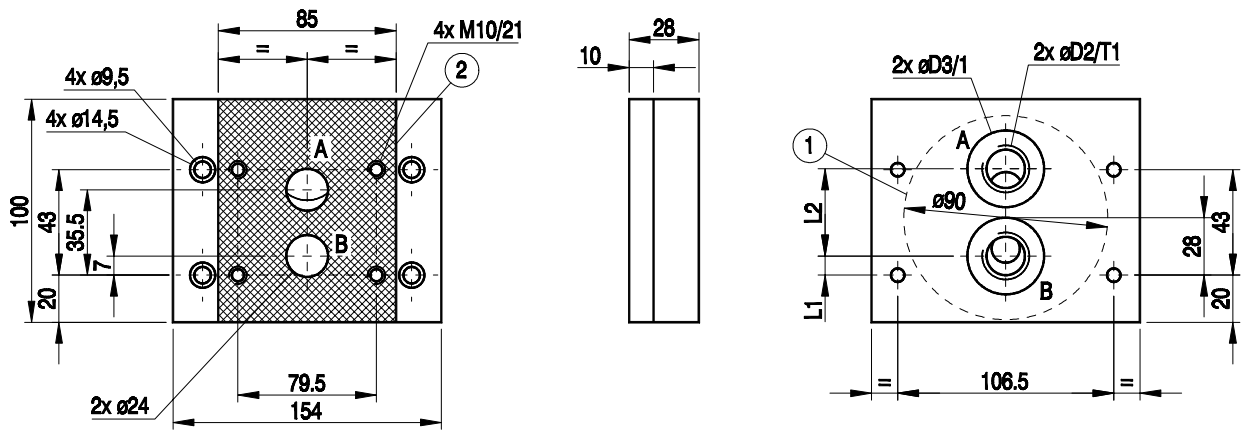

1 - Recess in subplate face
 2 - Connection face

Type	D1	D2	D3	T1	L1	L2
G23/ 01/ s	11,5	G 1/ 4	25	12	7	28,5
G41/ 01/ s	15	G 3/ 8	28	12	7	33
G24/ 01/ s	15	G 1/ 2	34	14	2	42
G23/ 02/ s	11,5	M14 x 1,5	24	15	7	28,5
G41/ 02/ s	15	M18 x 1,5	30	21	7	33
G24/ 02/ s	15	M22 x 1,5	36	18	2	42

Fitting of the valve to the subplate by means of the bolts M10 x 50 - 10.9 PN-74/M-82302 (DIN 912)
 with torque Md = 69 Nm
 The fixing bolts and subplate must be ordered separately.



Q-HYDRAULIKA, Rakovník
Rabasova 2281, 269 01 Rakovník, tel./fax: 313 514 718
e-mail: info@q-hydraulika.cz, www.q-hydraulika.cz