



# CHECK VALVE TYPE UZZB 20 FOR SUBPLATE MOUNTING

**WK  
450 351**

Size 20

up to 31.5 MPa

200 dm<sup>3</sup>/min

04.1999r.

Check valves type UZZB 20 are used to close hydraulic fluid flow in one direction and allow free flow in the opposite direction.

The valves are for subplate mounting and can be installed in systems in any positions together with a connection plate.

Sealing of interfaces is provided by O-rings which are included.

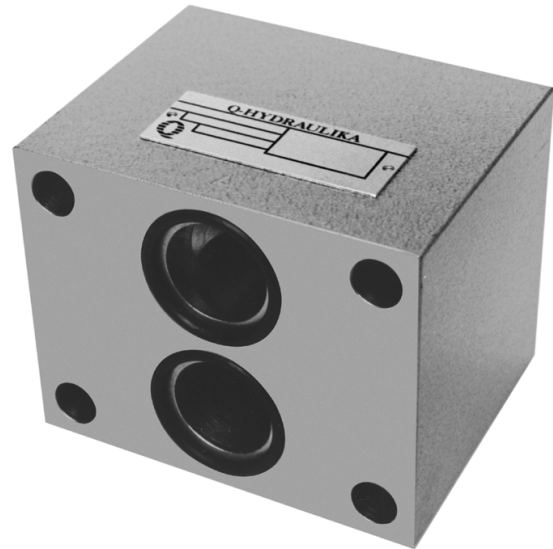

## DESCRIPTION OF OPERATION

In the check valve type UZZB 20 the closing element is a poppet 2 pushed on to the seat in the housing 1. Flowing through the valve in the direction A to B fluid lifts the poppet from its seat and permits free flow. Cracking pressure depends on initial spring tension.

In the opposite direction B to A the spring and the fluid push the poppet on to the seat and close the connection without leakage.

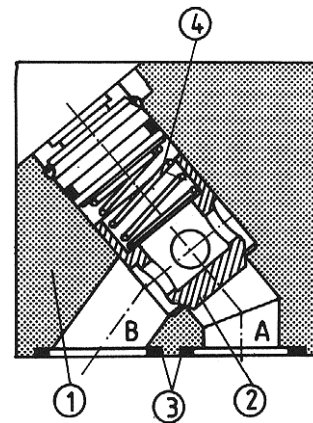

Item 3 - O-ring 29.2 × 3 - 2 pieces

## TECHNICAL DATA

Hydraulic fluid	Mineral oil or phosphate ester
Nominal fluid viscosity	37 mm <sup>2</sup> /s at the temperature of 328 K
Viscosity range	2.8 to 380 mm <sup>2</sup> /s
Optimum working temperature (fluid in a tank)	313 - 328 K
Fluid temperature range	243 - 343 K
Required fluid filtration	16 μm
Recommended fluid filtration	10 μm
Maximum working pressure	31.5 MPa
Cracking pressure	0.05; 0.1; 0.15 ; 0.3 MPa
Weight	3.1 kg

# OVERALL DIMENSIONS

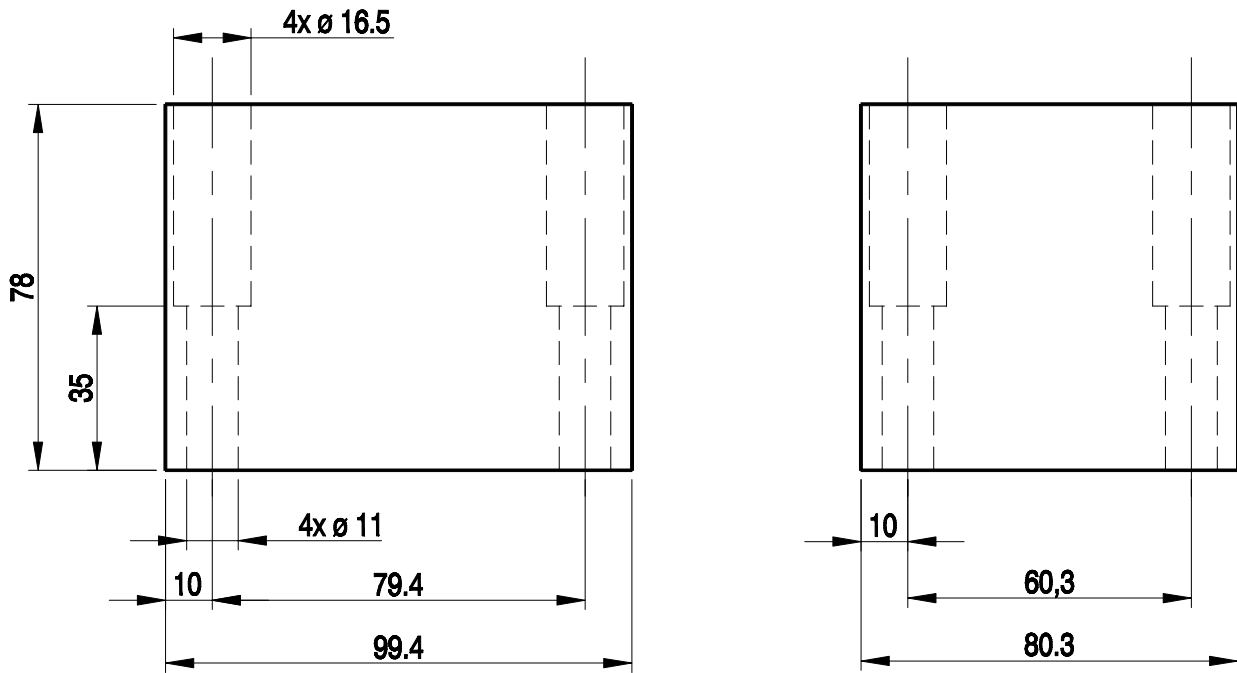

Admissible surface roughness and flatness deviation for a subplate face.

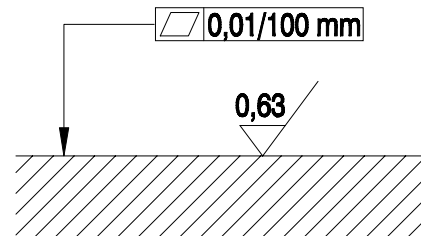

# PERFORMANCE CURVES, measured at $v = 41 \text{ mm}^2/\text{s}$ and $T = 323 \text{ K}$

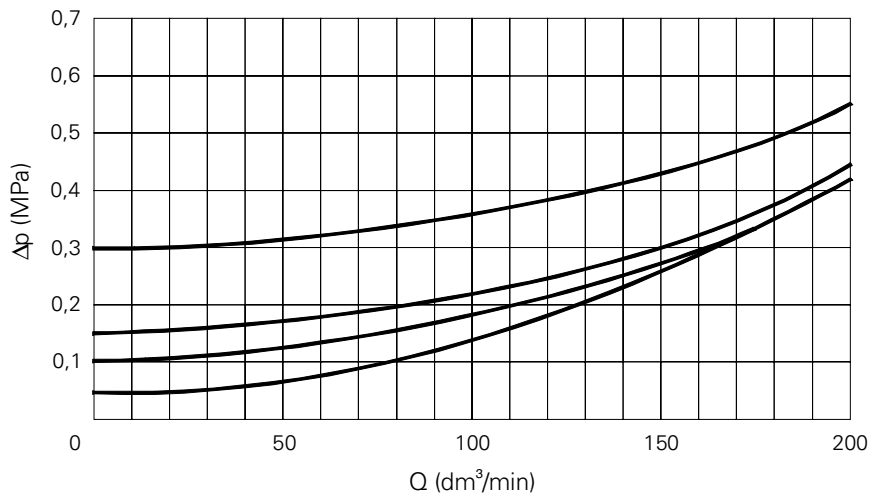

# SCHEME



Graphical symbol

# HOW TO ORDER

Orders coded in the way showed below should be forwarded to the manufacturer.



Series number :  
 20 = 20  
 (20-29) - installation and connection dimensions unchanged

Additional requirements in clear text  
 ( to be agreed with the manufacturer )

Cracking pressure  
 Without spring = 00  
 Cracking pressure 0.05 MPa = 05  
 Cracking pressure 0.10 MPa = 10  
 Cracking pressure 0.15 MPa = 15  
 Cracking pressure 0.30 MPa = 30

Sealing  
 Fluids on mineral oil base = no designation  
 Fluids on phosphate ester base = V

Coding example : UZZB 20 - 20/30

## CONNECTION DIMENSIONS FOR A SUBPLATE

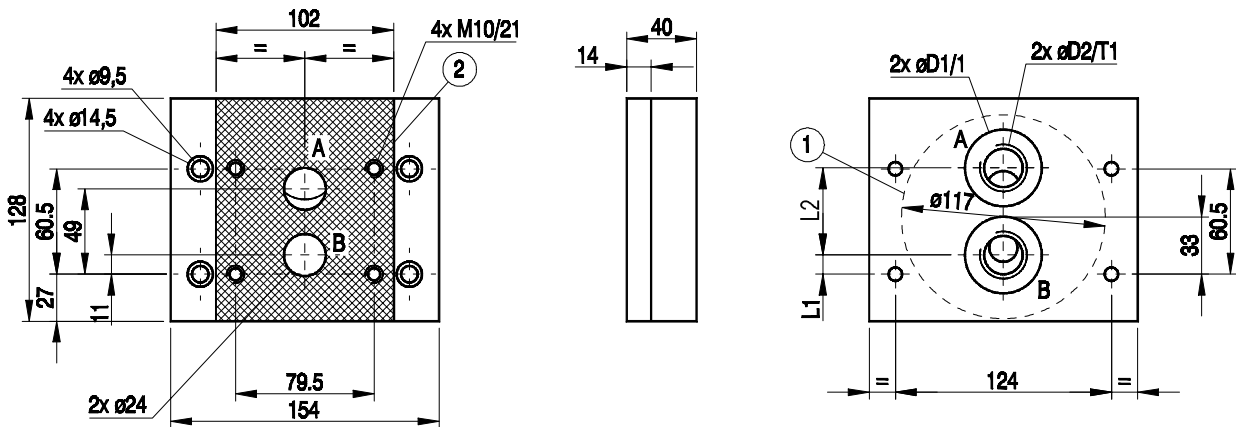

- 1 - Recess in subplate face
- 2 - Connection face

Type	D1	D2	T1	L1	L2
G25/ 01/ s	36	G 3/ 4	16	11	50
G26/ 01/ s	43	G 1	18	3	60
G25/ 02/ s	44	M27 x 2	20	11	50
G26/ 02/ s	49	M33 x 2	22	3	60

Fitting of the valve to the subplate by means of the bolts M10 x 50 - 10.9 PN-74/M-82302 ( DIN 912 )  
 with torque Md = 69 Nm  
 The fixing bolts and subplate must be ordered separately.



**Q-HYDRAULIKA, Rakovník**  
Rabasova 2281, 269 01 Rakovník, tel./fax: 313 514 718  
e-mail: [info@q-hydraulika.cz](mailto:info@q-hydraulika.cz), [www.q-hydraulika.cz](http://www.q-hydraulika.cz)