



CHECK VALVE TYPE UZZR

**WK
450 433**

Size 6 to 25

up to 32 MPa

04.1999r.

Check valves type UZZR provide leakage-free closure of hydraulic fluid flow in one direction and allow free flow in the opposite direction. Check valves type UZZR are designed for in-line mounting in any position.

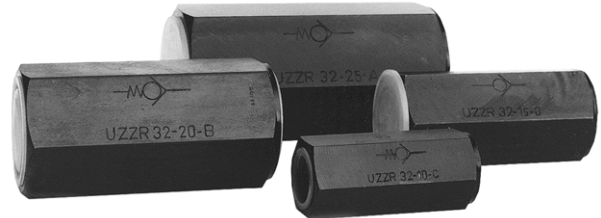

DESCRIPTION OF OPERATION

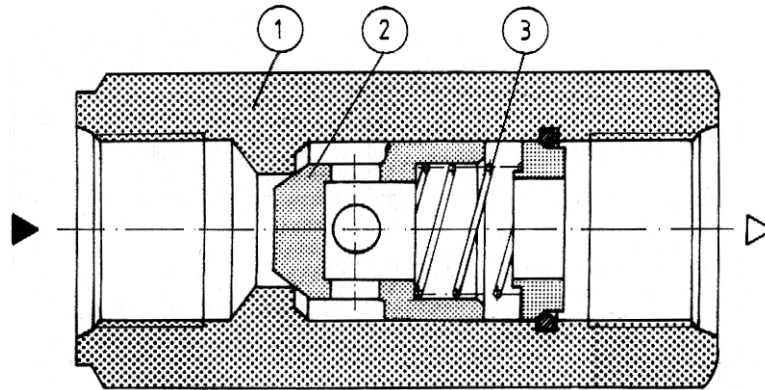

Fluid flowing through the valve overcomes the resistance of the spring 3 and causes the poppet 2 to lift. This allows free flow.

In the opposite direction the spring 3 and the fluid push the poppet 2 onto the seat in the housing 1 and close the connection.

TECHNICAL DATA

Hydraulic fluid	Mineral oil or phosphate ester				
Filtration	≤ 16 μm				
Maximum working pressure	32 MPa				
Nominal fluid viscosity	37 mm ² /s at the temperature of 328 K				
Viscosity range	2.8 to 380 mm ² /s				
Optimum working temperature (fluid in a tank)	313 - 328 K				
Temperature range	243 - 343 K				
Cracking pressure	Type A	Type B	Type C		
	0.05 MPa	0.15 MPa	0.3 MPa		
Nominal flow in dm ³ /min at V = 6 m ² /s	Nominal size				
	Size 6	Size 10	Size 16	Size 20	Size 25
	10	30	65	115	175

OVERALL DIMENSIONS

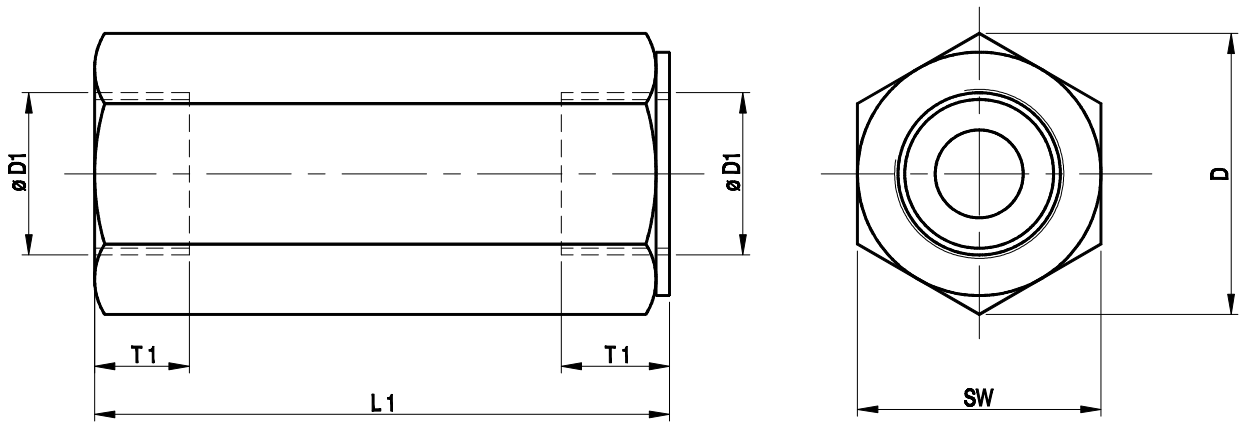

NG	6	10	16	20	25
D1	M16 x 1,5	M22 x 1,5	M33 x 2	M42 x 2	M48 x 2
D	25	34	47	57	69
L1	60	72	90	105	125
T1	16	18	22	24	26
SW	22	30	41	50	60
Weight kg	0,1	0,3	0,5	1,0	2,0

PERFORMANCE CURVES, measured at $v = 41 \text{ mm}^2/\text{s}$ and $T = 323 \text{ K}$

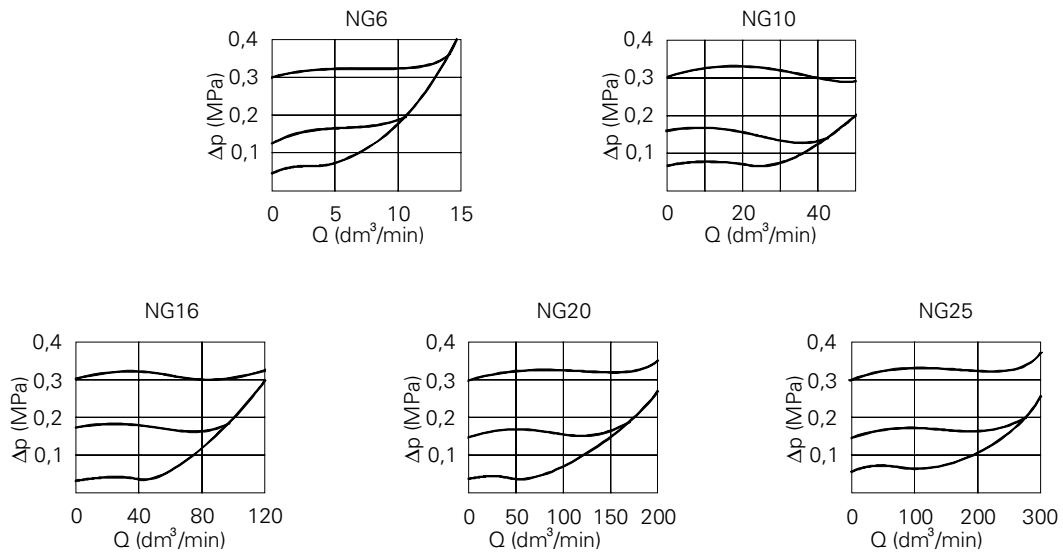

Pressure difference Δp related to flow Q at the particular cracking pressure.

SCHEME



Graphical symbol

HOW TO ORDER

Orders coded in the way showed below should be forwarded to the manufacturer.

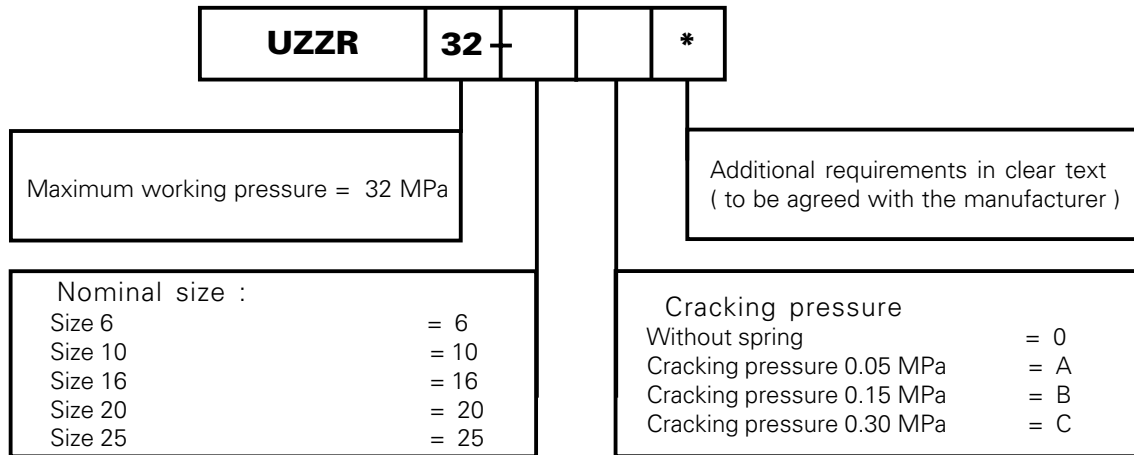

Coding example : UZZR32-6A

NOTES :



Q-HYDRAULIKA, Rakovník
Rabasova 2281, 269 01 Rakovník, tel./fax: 313 514 718
e-mail: info@q-hydraulika.cz, www.q-hydraulika.cz