



Directional spool valve type WMM 16 hand lever operated

**WK
450 209**

Size 16

35 MPa

180 dm³/min

04.1999r.

Directional spool valves are used to control the direction of fluid flow and thus the direction of movement or holding position of a user (cylinder or hydraulic motor).

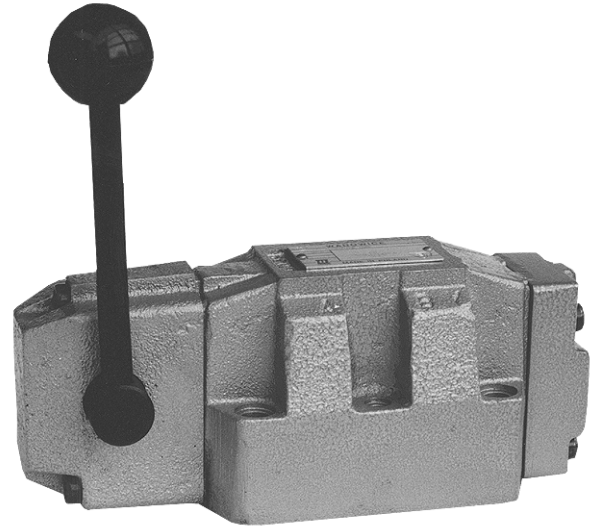

DESCRIPTION OF OPERATION

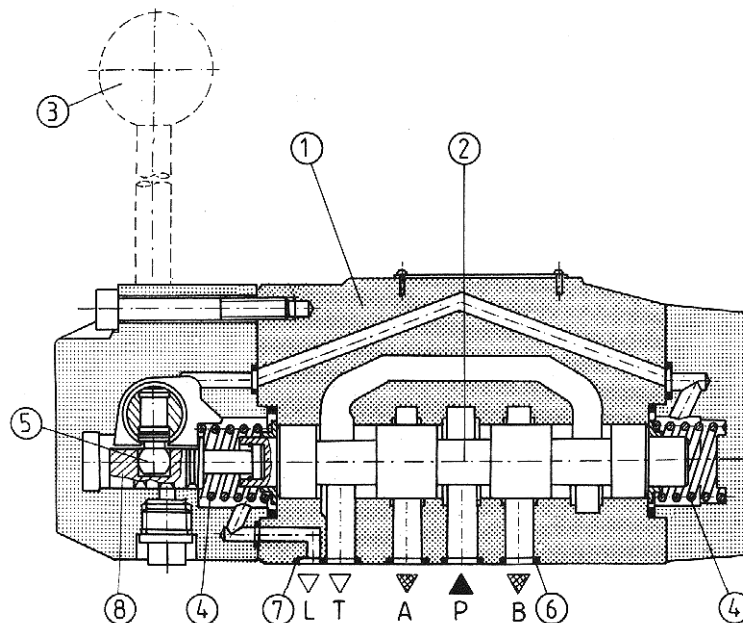

Annular ports are made around the longitudinal bore in the housing 1. The annular ports cut through the longitudinal bore forming control lands in the housing. The moveable control spool 2 is placed in the main port. If the spool is shifted, it connects or separates the ports in the housing. Various control functions result directly from shape of the control spool. Movement of the control spool is caused by a change

in position of the hand lever 3 with aid of the pins 5 and 8. The control spool together with the control elements are returned to their rest position by the centering spring 4 - in version with return springs.

The sealing rings 6 and 7 are installed between the valve and a subplate to prevent leakage.

TECHNAICAL DATA

Hydraulic fluid	Mineral oil, phosphate ester		
Required filtration	up to 16 μm		
Recommended filtration	up to 10 μm		
Nominal fluid viscosity	37 mm^2 at temp. of 328 K		
Viscosity range	2.8 to 380 mm^2/s		
Optimum working temperature (fluid in a tank)	313 - 328 K		
Fluid temperature range	243 - 343 K		
Maximum admissible operating pressure	Ports P, A, B		Port T
	35 MPa		25 MPa
Flow section in position „0”	Spool type Q	Spool type V	Spool type W
	16 % of nominal section	16 % of nominal section	3 % of nominal section
Operating force	With detent		With return springs
	approx. 40 N		max 70 N
Weight	7.5 kg		

OVERALL AND MOUNTING DIMENSIONS

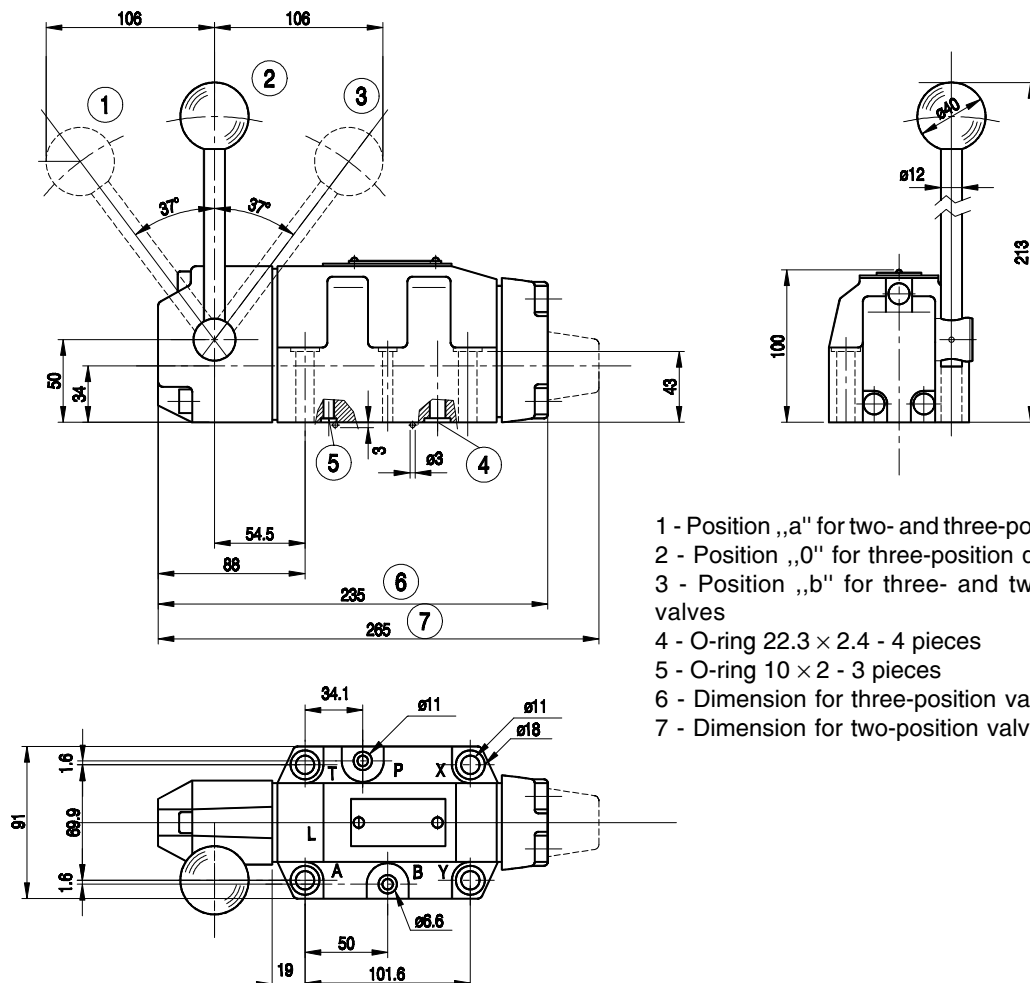

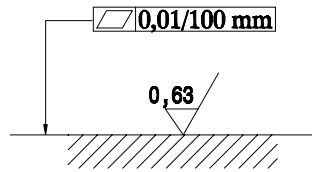

Admissible surface roughness and flatness deviation for a subplate face.

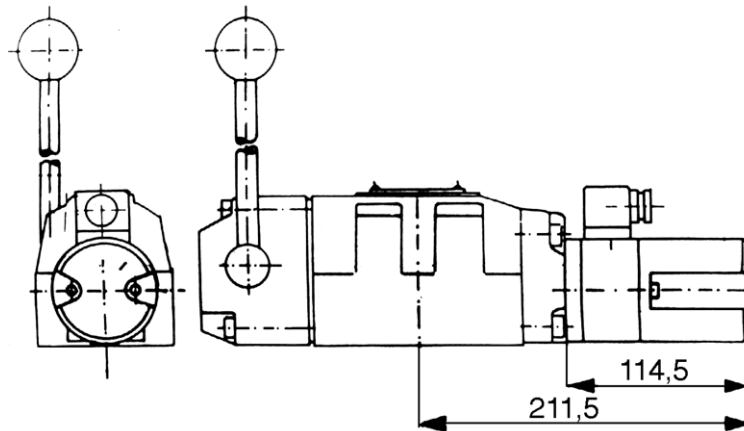

Limit switch - overall dimensions

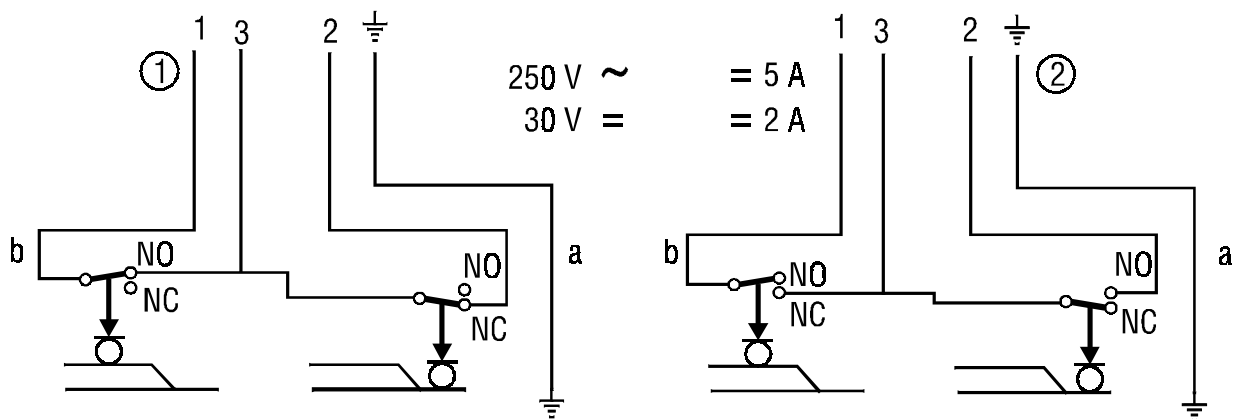

Electrical scheme for limit switch

- 1 - Scheme for limit switch normally closed 19
- 2 - Scheme for limit switch normally open 23

PERFORMANCE CURVES : measured at $v = 41 \text{ mm}^2/\text{s}$ and $T = 323 \text{ K}$

Flow resistance for various spool types

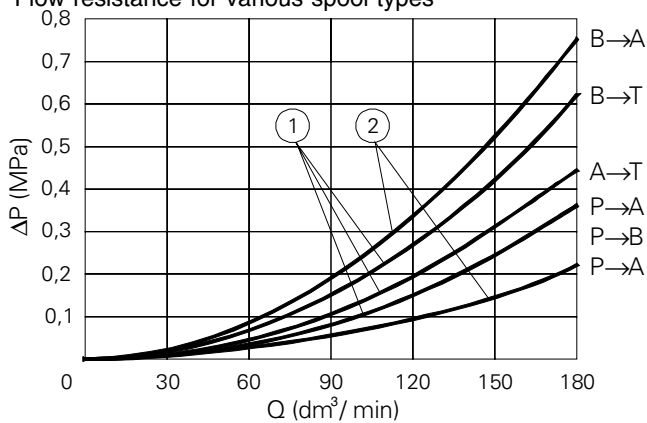

- 1 - Spool types E, R
- 2 - Spool type R (P to A and B to A)

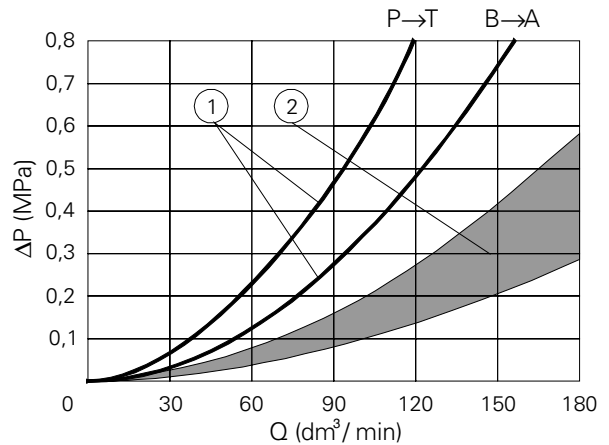

- 1 - Spool type S
- 2 - Other spool types

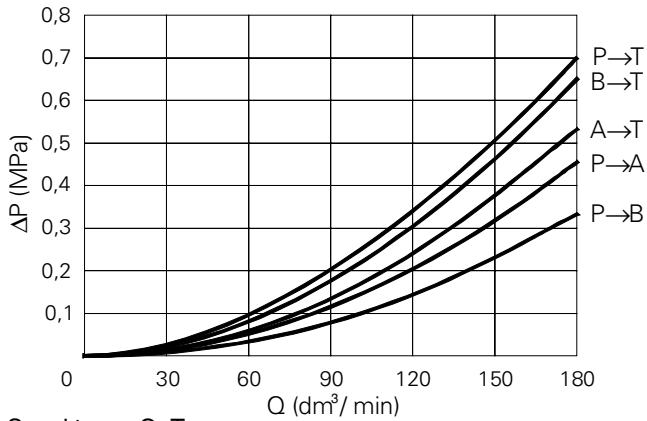

Spool types G, T

Flow limits

2 and 3-position valves, spring centered					
Spool types	Pressure (MPa)				
	7	14	21	28	35
E, J, L, M, Q, R, U, V, W, C, D, K, Z	180	180	180	180	170
F	125	100	80	70	65
G, H, S, T	125	115	90	80	70
2 and 3-position valves with detent					
All spool types	180	180	180	180	180

SCHEMES

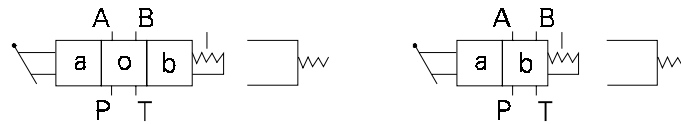

Hydraulic scheme

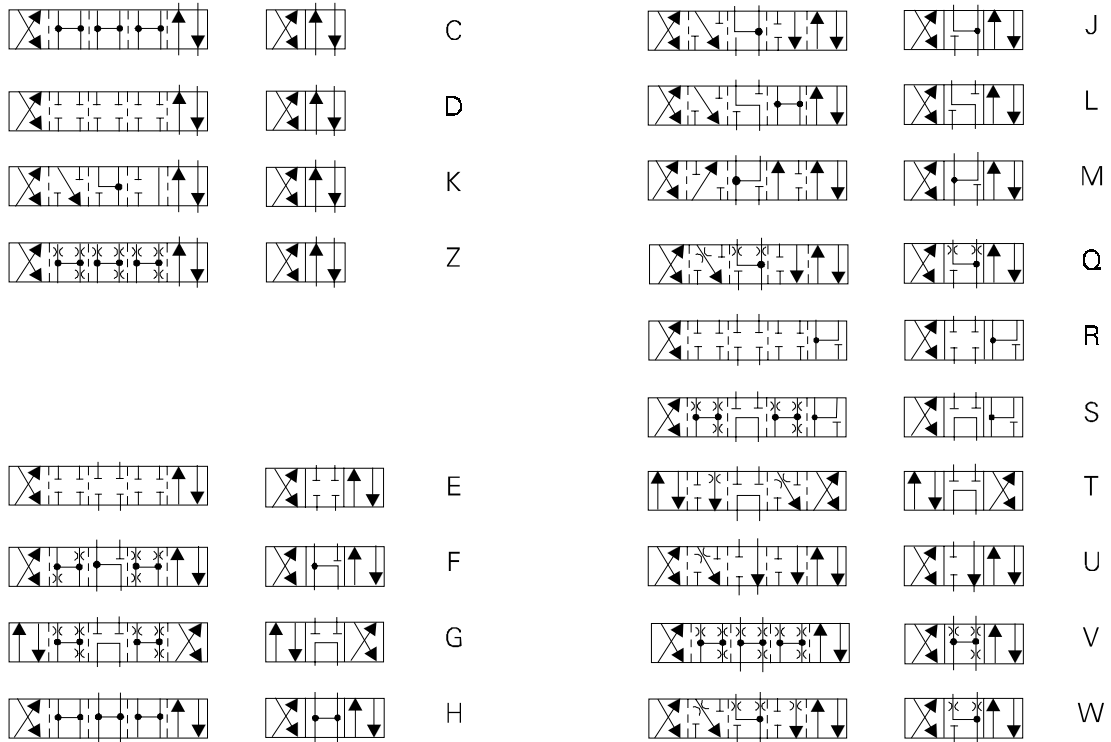

Schemes for control spools

HOW TO ORDER

Orders coded in the way showed below should be forwarded to the manufacturer.

H-4WMM 16 / / / *

Control spool type
See schemes on page 4

Additional requirements in clear text (to be agreed with the manufacturer)

Series number:
32 = 32
(32 - 39) - Installation and connection dimensions unchanged

Sealing
For fluids on mineral oil base = with no designation
For fluids on phosphate ester base = V

Control spool positioning
Spring centering = with no designation
With detent = F

Accessories
Limit switch (normally closed) = 19
Limit switch (normally open) = 23
Without limit switch = no code

Applicable only to three-position valves

Coding example : H-4 WMM 16E30/F

MOUNTING DIMENSIONS FOR SUBPLATE

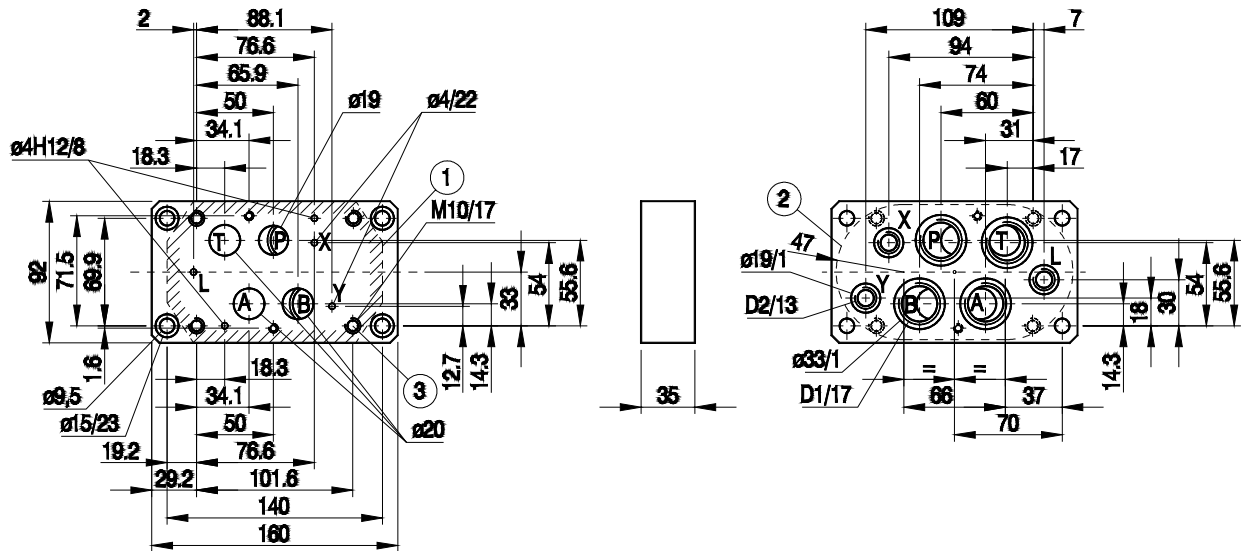

- 1 - Mounting face
- 2 - Recess in subplate face
- 3 - Threads fixing valve

Subplate type	Ø D1	Ø D2
G 172/01	G3/4	G1/4
G 172/02	M27 x 2	M14 x 1.5

Weight approx. 2.8 kg

