



Directional spool valve type WMM 5 hand lever operated

**WK
450 202**

04 1999

Size 5

31,5 MPa

16 dm³/min

Directional spool valves are used to control the direction of fluid flow and thus the direction of movement or holding position of a user (cylinder or hydraulic motor).

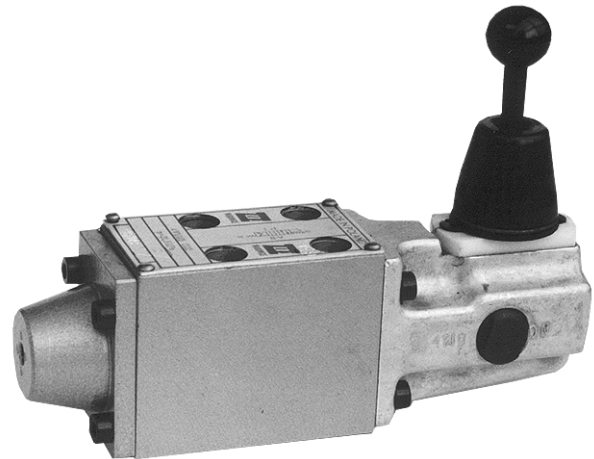

DESCRIPTION OF OPERATION

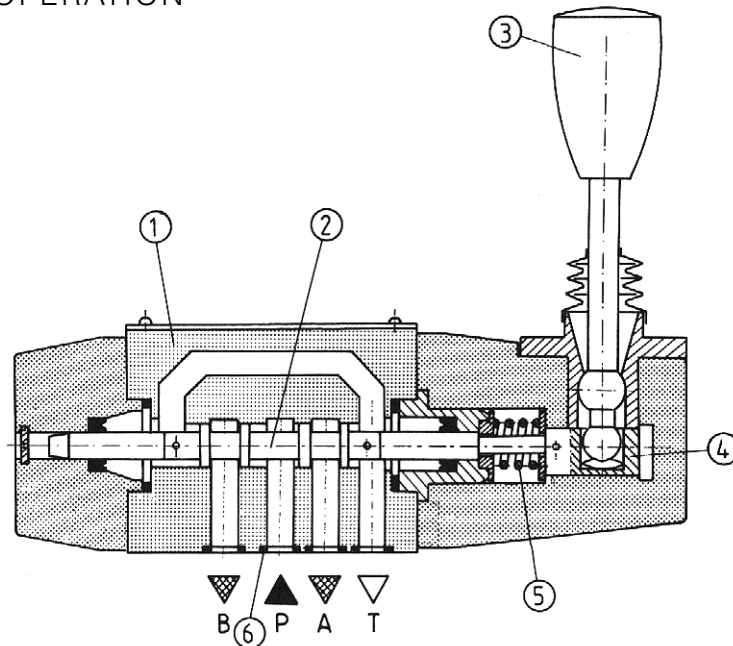

Annular ports are made around the longitudinal bore in the housing 1. The annular ports cut through the longitudinal bore forming control lands in the housing. The moveable control spool 2 is placed in the main port. If the spool is shifted, it connects or separates the ports in the housing. Various control functions result directly from shape of the control spool.

The movement of the spool results from a change in the position of the hand lever 3 with which the pin 4 is combined.

The directional valve is available with centering spring 5 or with detent.

Sealing of the directional valve to a subplate is achieved by means of suitable rings 6.

TECHNICAL DATA

Hydraulic fluid	Mineral oil, phosphate ester	
Required filtration	up to 16 µm	
Recommended filtration	up to 10 µm	
Nominal fluid viscosity	37 mm ² at temp. of 328 K	
Viscosity range	2.8 to 380 mm ² /s	
Optimum working temperature (fluid in a tank)	313 - 328 K	
Fluid temperature range	243 - 343 K	
Maximum operating pressure	Port P, A, B	Port T
	31.5 MPa	6 MPa
Flow section in position „0”	Spool type W	Spool type Q
	3 % of nominal section	6 % of nominal section
Weight	1 kg	

OVERALL DIMENSIONS

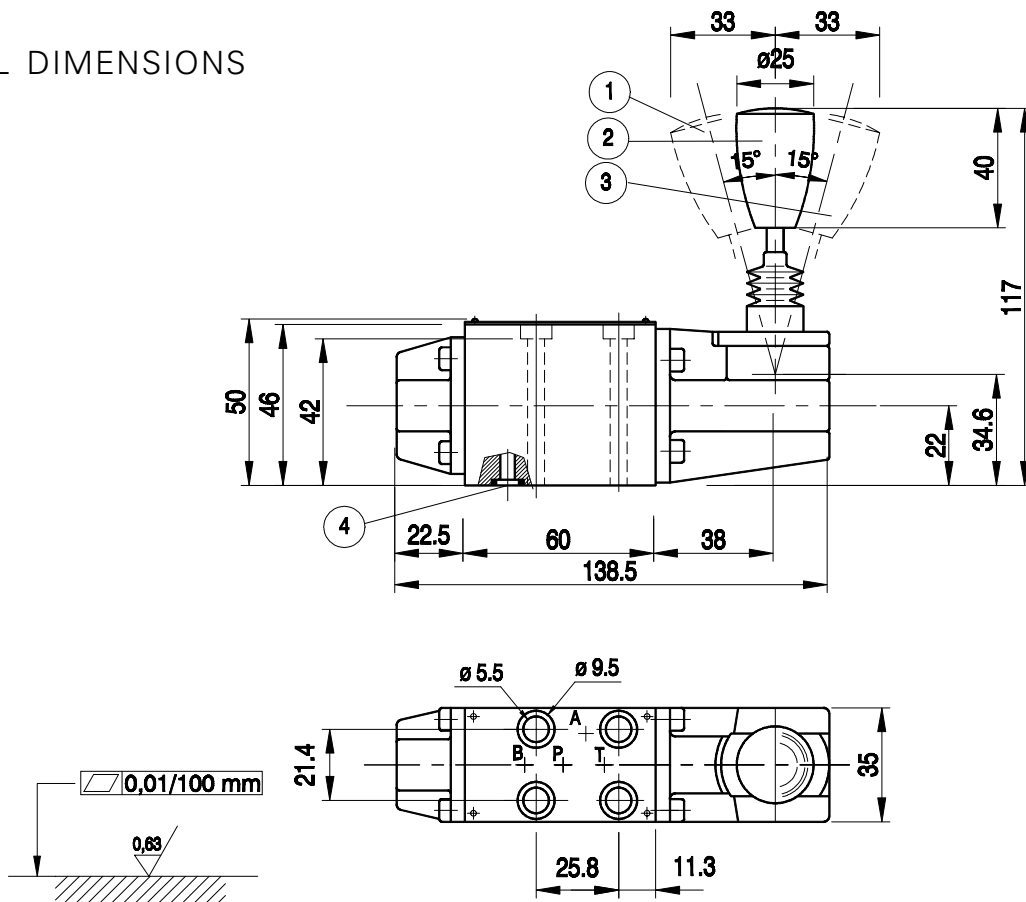

Admissible surface roughness and flatness deviation for a subplate face

- 1 - Position „b” for three-position directional valves and two-position spool N/OF
- 2 - Position „b” for two-position directional valves (except for spool type N/OF) and position „0” for three - position valves.
- 3 - Position „a” for two- or three-position directional valves
- 4 - O-ring 7 × 1.5 - 4 pieces

PERFORMANCE CURVES : measured at $v = 41 \text{ mm}^2/\text{s}$ and $T = 323 \text{ K}$

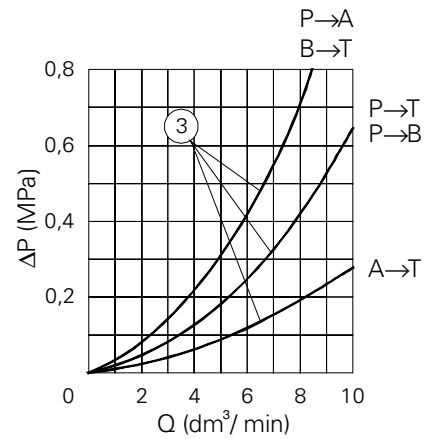
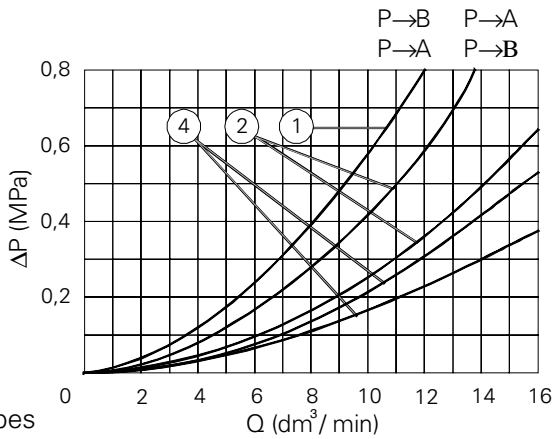

- 1 - Spool type B
- 2 - Spool type R
- 3 - Spool type G
- 4 - Other spool types

SCHEMES

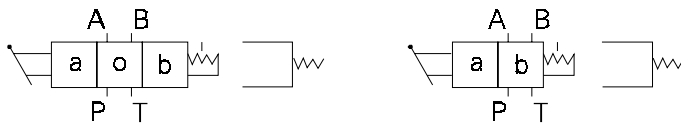

Scheme for directional valve two- or three-position, manually operated.

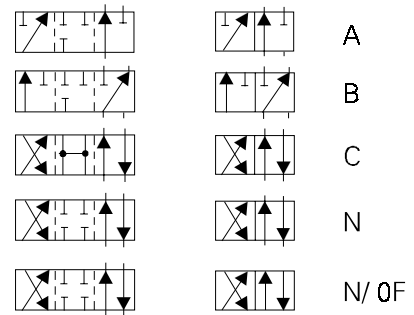

Schemes for control spools and their overlap positions.

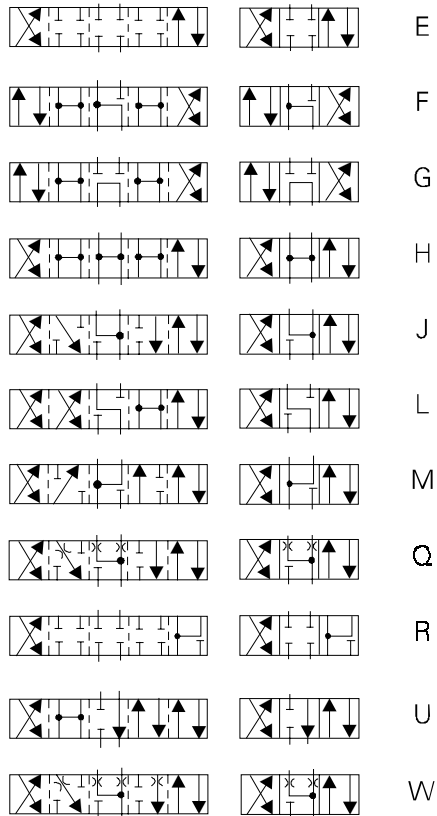

HOW TO ORDER

Orders coded in the way showed below should be forwarded to the manufacturer.



Number of service ports
 3 = 3
 4 = 4

Additional requirements in clear text (to be agreed with the manufacturer)

Control spool type
 See schemes on page 3

Sealing
 For fluids on mineral oil base = with no designation
 For fluids on phosphate ester base = V

Series number:
 1.2 = 1.2
 (1.0 - 1.9) - Installation and connection dimensions unchanged

Control spool positioning
 Spring centering = with no designation
 With detent = OF

Coding example : 4 WMM5E1.2/F

MOUNTING DIMENSIONS FOR SUBPLATE

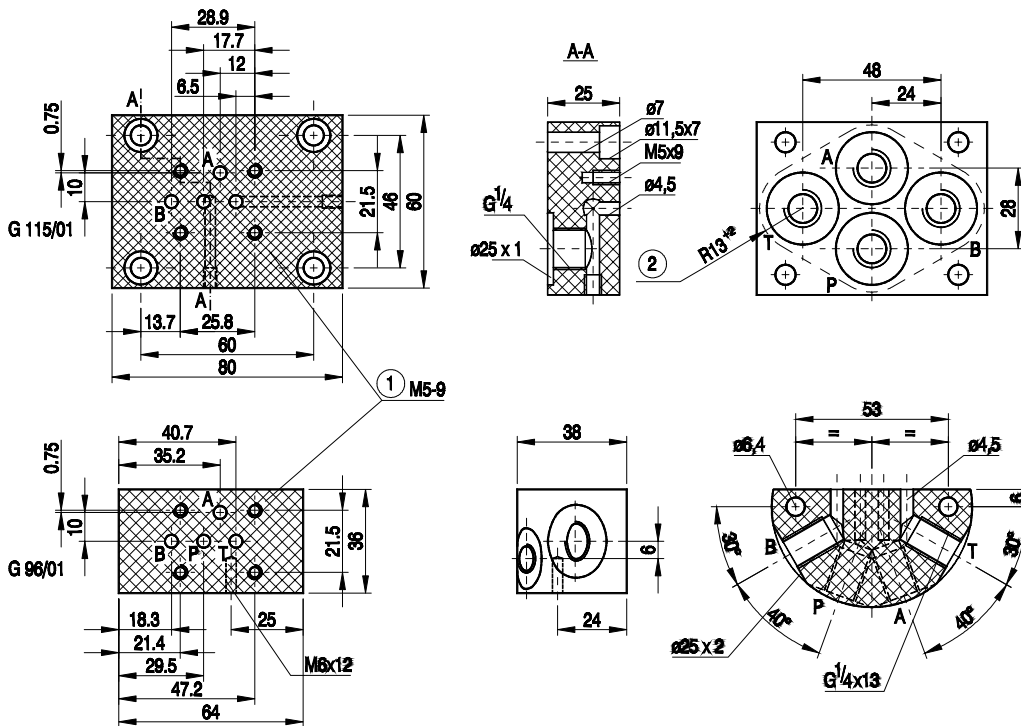

1 - Mounting face
 2 - Recess in subplate face
 Note : Subplate and mounting bolts must be ordered separately

Subplate weight - approx. 0.7 kg

Bolts mounting valve to subplate	Torque
4 × M5 × 50 -10.9 per PN-74/M-82302 (DIN 912)	9 Nm



Q-HYDRAULIKA, Rakovník
 Rabasova 2281, 269 01 Rakovník, tel./fax: 313 514 718
 e-mail: info@q-hydraulika.cz, www.q-hydraulika.cz