



CHECK VALVE TYPE Z2S16 SANDWICH PLATE, PILOT OPERATED

**WK
450 310**

Size 16

up to 31.5 MPa

200 dm³/min

04.1999r.

Pilot operated double check valve type Z2S16 serves to shut-off an oil flow in one direction and allow free flow in the opposite direction. They can also be opened in the direction of closure.

These valves are mostly used :

- to relieve a working circuit under pressure
- to prevent a load from falling in the case of a line rupture
- to prevent creep movements of hydraulically stressed users.

These valves are generally fitted as an intermediate element between the control valve and the subplate. Sealing of interfaces is provided by o-rings, which are included. The valve can be installed in any position.

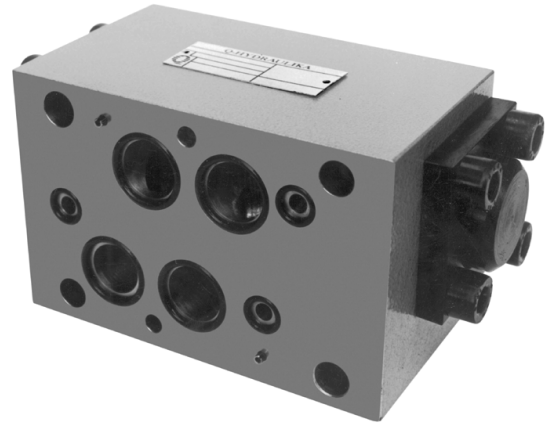

DESCRIPTION OF OPERATION

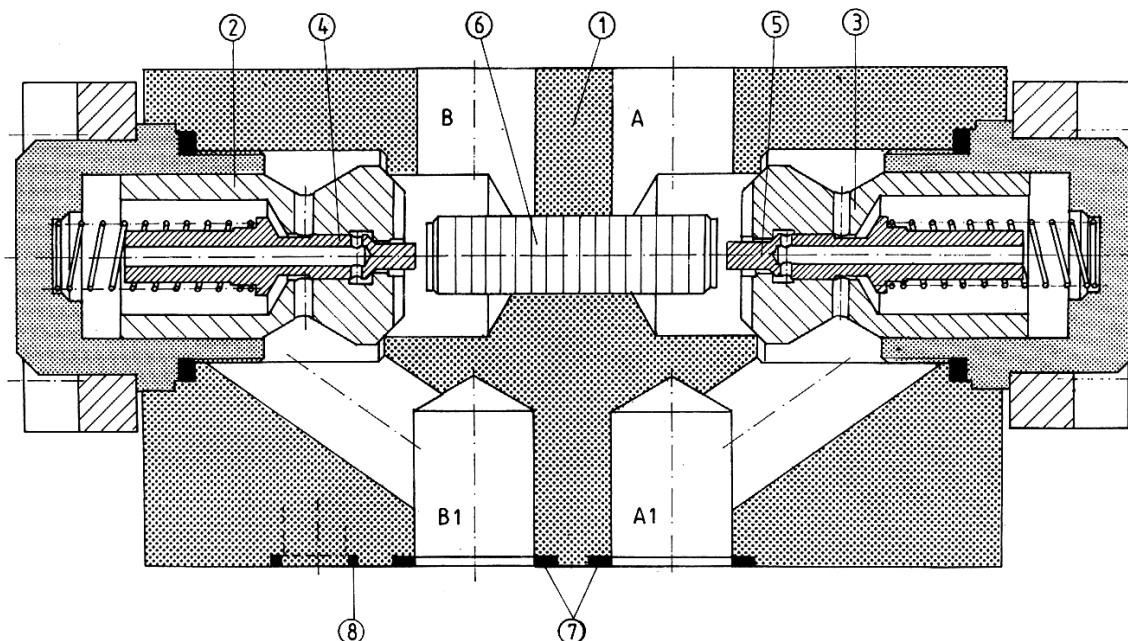

Item 7 - O-ring 22.3 × 2.4 - 4 pieces

Item 8 - O-ring 10 × 2 - 3 pieces

Pilot operated double check valve type Z2S16 is obtained by fitting two pilot operated check valves (2) and (3) equipped with pilot opening poppets (4) and (5) in one housing (1).

There is free flow from A to A1 or/and B to B1 while flow is blocked from A1 to A and/or B1 to B. When fluid flows through the valve from A to A1, the piston (6) is moved to the right and the decompression poppet (4) is pushed from its seat,

followed by the full opening of the main poppet of (3). The connection from B1 to B is now open. In the similar way the valve operates in the direction B to B1. By using the pilot opening poppets rapid and smooth decompression of the compressed fluid is achieved.

Pressure dissipation at ports A or B causes both valves to close.

In order to ensure safe closing of the valves both user ports A and B should be connected with a return line.

TECHNICAL DATA

Hydraulic fluid	Mineral oil or phosphate ester
Nominal fluid viscosity	37 mm ² /s at the temperature of 328 K
Viscosity range	2.8 to 380 mm ² /s
Optimum working temperature (fluid in a tank)	313 - 328 K
Fluid temperature range	253 - 343 K
Maximum working pressure	31.5 MPa
Cracking pressure	0.1 MPa
Area ratio (valve surface / piston surface)	4 : 1
Area ratio (pilot opening poppet surface / piston surface)	1 : 4
Weight	6.8 kg

OVERALL AND CONNECTION DIMENSIONS

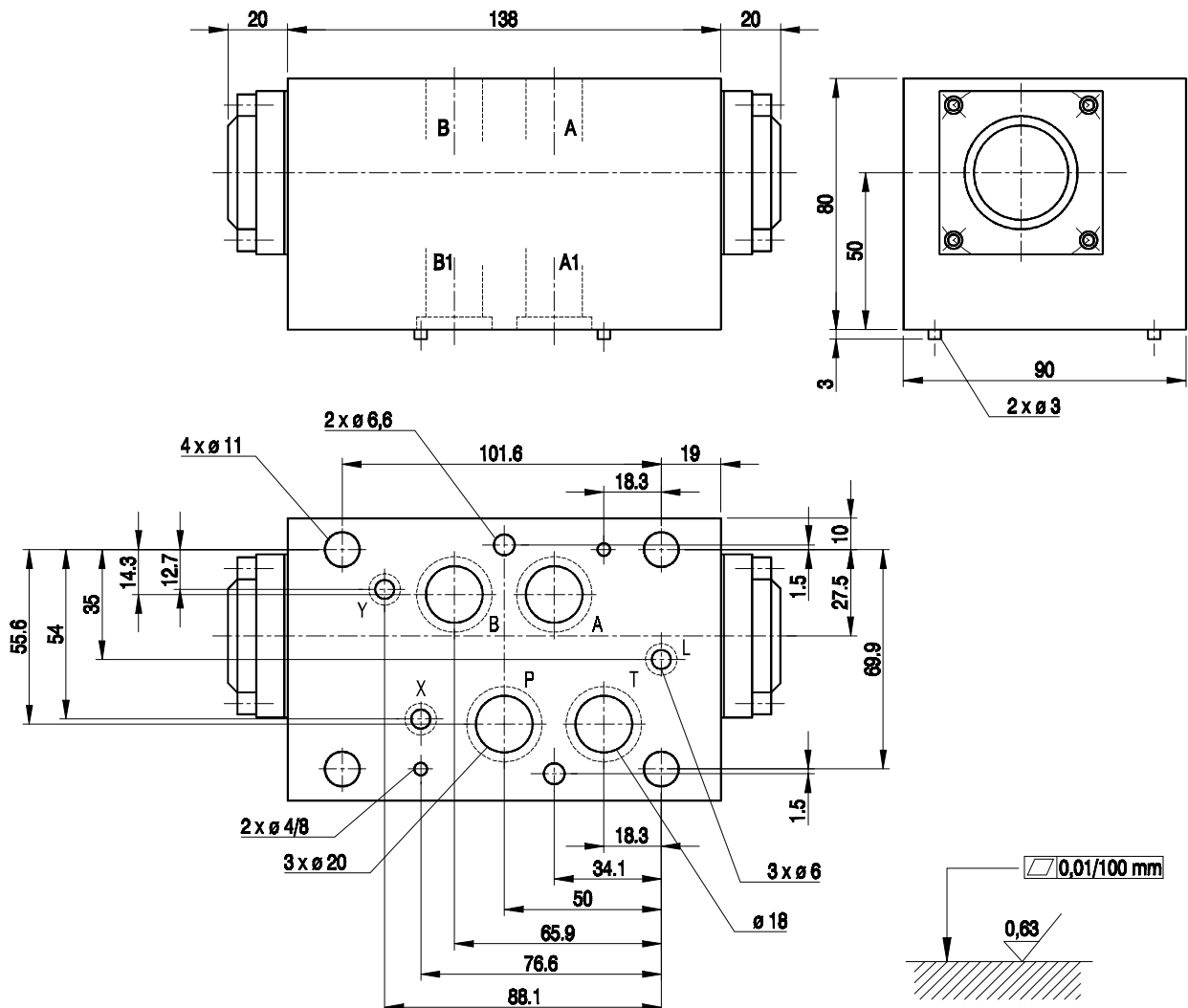

Admissible surface roughness and flatness deviation for a subplate face.

PERFORMANCE CURVES, measured at $v = 41 \text{ mm}^2/\text{s}$ and $T = 323 \text{ K}$

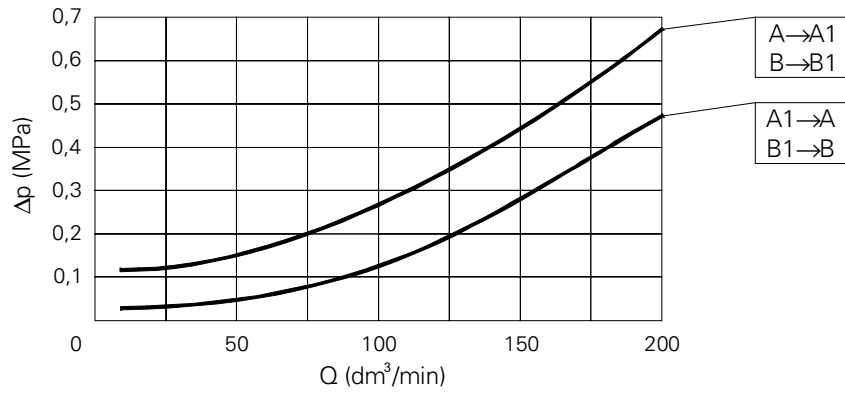

SCHEMES

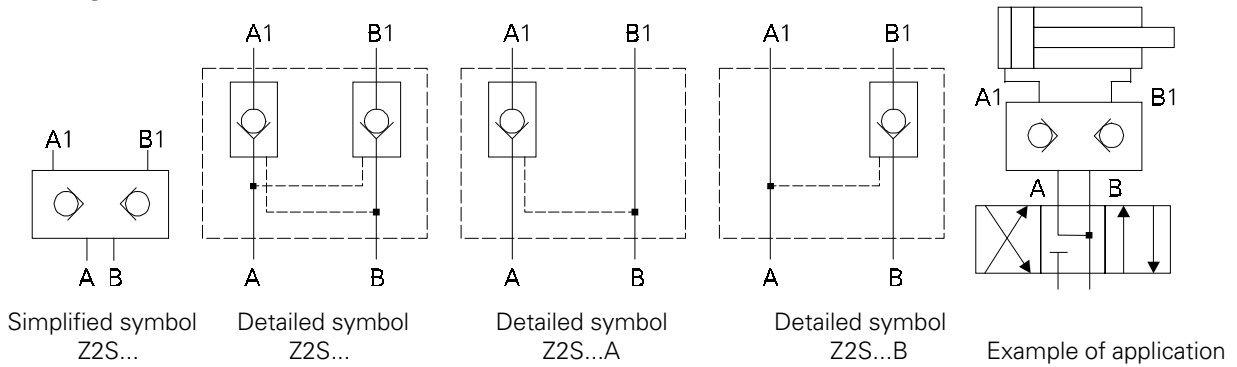

HOW TO ORDER

Orders coded in the way showed below should be forwarded to the manufacturer.

Z2S16 - - / *

Version	
	with two valves = -
	with one valve at port A = A
	with one valve at port B = B

Additional requirements in clear text
(to be agreed with the manufacturer)

Series number	= 10
(10 - 19) - installation and connection dimensions unchanged	

Sealing
Fluids on mineral oil base = no designation
Fluids on phosphate ester base = V

Coding example : Z2S10 - 10



Q-HYDRAULIKA, Rakovník
Rabasova 2281, 269 01 Rakovník, tel./fax: 313 514 718
e-mail: info@q-hydraulika.cz, www.q-hydraulika.cz