

### 10C...X053...

G = trubkový závit (standard)  
 M = metrický závit

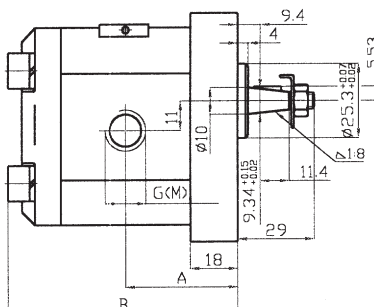
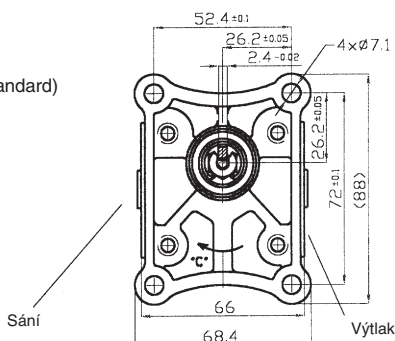

Typ	Dodávané množství	Jmenovitý tlak	Rozměry					
			A	B	Sání		Výtlač	
	cm <sup>3</sup>	bar	mm		G	M	G	M
					mm		mm	
10C1X053G nebo M	1	250	39,1	81,0	3/8"	M16×1,5	3/8"	M16×1,5
10C1,25X053G nebo M	1,25	250	39,5	82,0				
10C1,60X053G nebo M	1,6	250	40,3	83,6				
10C2X053G nebo M	2	250	41,1	85,2				
10C2,50X053G nebo M	2,5	250	42,1	87,2				
10C3,15X053G nebo M	3,15	250	43,5	89,8	1/2"	M20×1,5	3/8"	M16×1,5
10C3,65X053G nebo M	3,65	250	44,4	91,9				
10C4,2X053G nebo M	4,2	250	45,5	94,1				
10C5X053G nebo M	5	250	47,1	97,2				
10C5,70X053G nebo M	5,7	200	48,5	100,1				
10C6,10X053G nebo M	6,1	200	49,4	101,8				

### 20C...X016...

G = trubkový závit (standard)  
 M = metrický závit

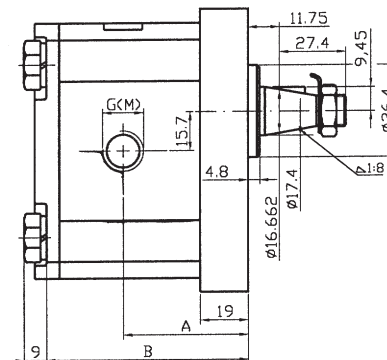
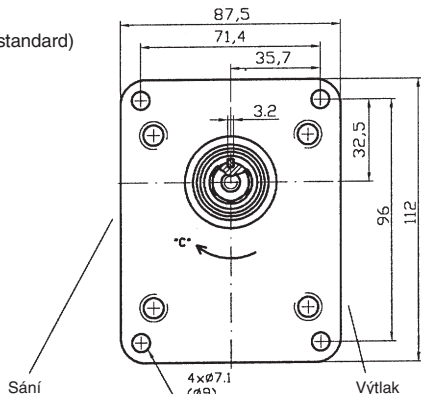

Typ	Dodávané množství	Jmenovitý tlak	Rozměry						
			A	B	Sání		Výtlač		
	cm <sup>3</sup>	bar	mm		G	M	G	M	
					mm		mm		
20C4,5X016G nebo M	4,5	250	42,5	80	1/2"	3/4"	M20×1,5	1/2"	M16×1,5
20C6,3X016G nebo M	6,3	250	42,5	80					
20C8,2X016G nebo M	8,2	250	42,5	80					
20C10X016G nebo M	10	250	47	89					
20C11X016G nebo M	11,3	250	48	91,1					
20C12X016G nebo M	12	250	48,7	92,3					
20C14X016G nebo M	14	250	50,2	95,4	3/4"	M20×1,5	1/2"	M16×1,5	
20C15X016G nebo M	15	250	51	96,9					
20C16X016G nebo M	16	250	51,8	98,6					
20C19X016G nebo M	19	200	54	103,5					
20C22X016G nebo M	22	200	56,5	108,5					
20C25X016G nebo M	25	160	59,2	113,4					